

# JIASHAN HUACHENG OILLESS BEARING CO., LTD

## 嘉善华承无油轴承有限公司

Rigorous work attitude  
casts Huacheng's  
excellent quality  
严谨的工作态度铸就  
华承优异的品质

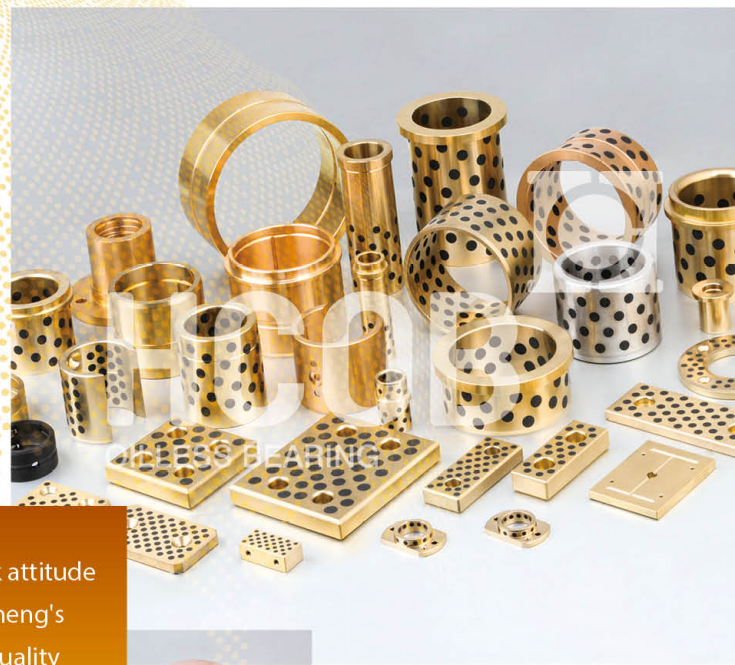

**Huacheng Bearing**

**HCOB**  
OILLESS BEARING

## 为全球工业提供各种自润滑轴承解决方案 Your Partner for Self-lubricating Bearing Application



### 公司简介

嘉善华承无油轴承有限公司地处于长三角地区的嘉善县干窑镇，环境优美，交通便利。公司长期致力于无油自润滑轴承和实体浇铸铜套的开发与设计，目前公司主要产品有：SF无油润滑轴承、JF双金属轴承、FB青铜轴承、JDB镶嵌固体润滑轴承等16个系列产品，已在高温、高速等多种场合进行了使用。公司拥有一支高素质、强劲的技术队伍和齐全、精良的机械加工设备，配备有精密检验和试验设备，产品具有较强的市场竞争能力。配备有使产品质量得到有效保证各类加工和检测设备，同时提供了一流的售后服务，深受客户好评与信赖。

我们将本着“质量第一、诚信为本”的经营理念，在以后的发展历程中一如既往的为您提供优质的产品和完善的售后服务。



## Introduction

JIASHAN HUACHENG OILLESS BEARING CO., CTD. is located in Jiashan, Zhejiang Yangtze River Delta, which is of Beautiful environment, convenient transportation. We have been committed to design of oilless bushing and solid bronze production. At present our main products are related to 16 series, such as SF Boundary bushing, JF Bi-metal bushing, FB wrapped bronze bushing as well as JDB bronze bushing with graphite plugged-in, which are used in high-temperature and speed conditions. Our company is equipped with quality technicians' team, well-equipped production and inspection facilities. The products are of competitive pricing and high quality. We offer best service and being trustful supplier.

We promise to be in the "quality first, integrity-based" business philosophy, in the future course of development, as always, to provide you with quality products and perfect after-sales service.





生产全景  
Production panorama



冲压机床  
Stamping machine

## PRODUCTION EQUIPMENT

# Rigorous work attitude creates Huacheng's excellent quality

## 严谨的工作态度铸就 华承优秀的品质

我们的承诺是始终不渝地创造新业绩，以维持我们在无油轴承领域卓越供应商的地位。

完善的品质保证体系，精密的检测设备，优秀的品质资源，三位一体的专业保障，构建华承轴承高品质的坚实的堡垒。

随着全球经济一体化的进程加速，华承人深知技术创新是企业发展的源泉与动力。雄厚的技术力量与自身的技术资源是华承不断壮大的坚实基础。

Our commitment is to unswervingly create new performance in order to maintain our position as an excellent supplier in the field of oil-free bearings.

A complete quality assurance system, sophisticated testing equipment, excellent quality resources, and three-in-one professional guarantee build a solid fortress of high-quality Huacheng Bearings.

全自动倒角机、卷圆机  
Automatic chamfering machine, rolling machine



检验检测  
Inspection and testing



卷制类车间全景  
Panoramic view of rolling workshop



JDB车间全景  
JDB workshop panorama

As the process of global economic integration accelerates, Huacheng people know that technological innovation is the source and driving force of enterprise development. The strong technical force and its own technical resources are the solid foundation for Huacheng's continuous growth.



CNC 加工设备  
Processing equipment



目录  
Catalogue



**Introduction**

企业简介  
Enterprise Brief  
Introduction

企业简介 Introduction

P1-P4



**SF-1**

金属塑料复合自润滑轴承  
Metal-Polymer  
Self-Lubricating  
Composite Bearings

SF-1 / SF-1B / SF-1D / SF-1S / SF-1SS

简介 Introduction

P6

技术参数 Technology

P7

尺寸及公差 Size & tolerance

P8-11



**SF-2**

金属塑料边界润滑轴承  
Metal-Polymer  
Marginal Lubricating  
Bearings

SF-2 (黑) / SF-2Y (黄) / SF-2H (红) /  
SF-2L (蓝) / SF-2P (PEEK)

简介 Introduction

P12

技术参数 Technology

P13

尺寸及公差 Size & tolerance

P14-16



**JF-800**

双金属复合轴承  
Bi-Metallic Composite  
Bearings

JF-820 / JF-800 / JF-720 / JF-700 /  
JF-20 / FB08G

简介 Introduction

P17

技术参数 Technology

P18-19

尺寸及公差 Size & tolerance

P20-23



**FB-090**

青铜卷制轴承  
Bronze Wrapped Bearings

FB090 / FB091 / FB092 / FB094 /  
FB09G

简介 Introduction

P24

技术参数 Technology

P25-26

尺寸及公差 Size & tolerance

P27-32



**JDB**

固体自润滑轴承  
Metallic Self-Lubricating  
Bearings

JDB-1 / JDB-2 / JDB-3 / JDB-4 / JDB-5

简介 Introduction

P38

技术参数 Technology

P39

尺寸及公差 Size & tolerance

P40-46

## SF-1 金属塑料自润滑复合轴承 SF-1 Metal-polymer self-lubricating composite bearings



### 结构特性 Structure Characteristics

SF-1 金属复合自润滑材料以优质低碳钢为基板，中间烧结球形多孔铜粉层，表面轧制以 PTFE 为主的耐磨润滑材料作为轴承工作层，这种材料具有优异的机械承载能力，中间铜粉层不但可以及时传递轴承运行过程中产生的热量，同时也提高了塑料层与基板的结合强度。PTFE 设计适用于完全干摩擦状态，并根据润滑情况、摩擦系数和耐久性要求开发了多种材料。华承的 PTFE 金属复合材料在外部润滑或者不润滑的情况下，都能在最广泛的载荷、速度以及温度范围内提供最好的表现。

SF-1 Metal-polymer self-lubricating composite materials consist of metal backing sintered porous bronze with PTFE polymer as working layer. The metal backing provides mechanical strength, while the bronze sinter layer provides a strong mechanical bonding between the backing and the bearing lining, the PTFE polymer offers exceptional low friction even under dry condition and the thermoplastic polymer is generally designed to operate with marginal lubrication. The construction promotes dimensional stability and improves the thermal conductivity. This material meets the demanding criteria for long life and trouble-free performance with or without lubrication.

### 产品应用 Application

农业机械：拖拉机、联合收割机、农作物喷雾器、推土机、平地机等；  
汽车行业：动力转向泵、转向器推力垫片、盘式制动器、减震器、门铰链、雨刮器、椅子调角器、空气阀以及电磁阀等；  
办公商务机械：复印机、传真机、打印机、邮件处理机等；  
液压元件和阀门：齿轮泵、柱塞泵、叶片泵，球阀、蝶阀，气缸、油缸以及其他液压元件等；  
家用电器：冰箱、空调、吸尘器、缝纫机、清洗机、微波炉和健身器材等；  
以及其它物流机械、包装机械、纺织机械、港口机械、矿产机械和森林机械等等。

Automotive: tractors, crop sprayers, earthmovers, auto machines, specific uses in power steering cylinders, steering gear thrust washers, disc brakes, shock absorbers, windshield wiper motor...  
Business machines: duplicator, fax machine, automatic printing devices, mail processing machinery...  
Hydraulics and valves: pumps including gear, rotary, water, axial piston, and other types, ball, butterfly, poppet steam, and other valves and valve trunnions...  
Home appliances: tape recorders, refrigerators, air conditioners, cleaners, polishers, sewing machines, ovens, dishwashers, clothes washing machines...And materials handling, marine engine, packaging, textile equipment, tools...etc.

实际运用中根据使用环境、工况和环保要求的不同，低碳钢板可以改为铜板或不锈钢板，内表面塑料层可以选择 PTFE 含铅或者不含铅材料以及其他高分子填充物，外表可以镀锡或者镀铜。产品范围包括：SF-1、SF-1B、SF-1D、SF-1S、SF-1SS。

According to the different working conditions and environmental protection, there are steel backing, bronze backing, stainless steel backing can be chosen, different type of alloy can be chosen, the PTFE layer with polymer filler and it is lead free, the Surface tin or copper plating. product range includes SF-1、SF-1B、SF-1D、SF-1S、SF-1SS.

有关数据 Date	代号 Grade	SF-1	SF-1B	SF-1D	SF-1S	SF-1SS
	材料 Material	碳钢/Steel+铜粉/ Bronze+(PTFE+Pb+ 填料/Filler)	铜板/Bronze+铜粉/ Bronze+(PTFE+Pb+ 填料/Filler)	碳钢/Steel+铜粉/ Bronze+(PTFE+Pb+ 填料/Filler)	不锈钢Stainless+铜 粉/Bronze+(PTFE+填 料/Filler)	不锈钢Stainless (PTFE+Pb+填料/ Filler)
除了目录中显示的标准产品外，还可以提供非标产品或根据客户要求订购。 We can also develop according to customers special request while out of this table.						
最大承载压力 P Load capacity P (干摩擦) (Dry friction)	静载 N/mm <sup>2</sup> Static load	250	250	250	250	250
	动载 N/mm <sup>2</sup> Dynamic load	140	140	140	140	140
	摇摆 N/mm <sup>2</sup> Oscillation Load	60	60	60	60	60
最大线速度V Max line speed V	干摩擦 m/s Dry friction	2.5	2.5	2.5	2.5	2
	油润滑 m/s Oil lubrication	>5	>5	>5	>5	>5
最高PV值 PV value limit (干摩擦) (Dry friction)	干摩擦 N/mm <sup>2</sup> ·m/s Dry friction	1.8	1.8	1.8	1.8	1.8
	油润滑 N/mm <sup>2</sup> ·m/s Oil lubrication	3.6	3.6	3.6	3.6	3.6
摩擦系数u Friction coef u	干摩擦 Dry friction	0.08~0.20	0.08~0.20	0.08~0.20	0.08~0.20	0.08~0.20
	油润滑 Oil lubrication	0.02~0.12	0.02~0.12	0.02~0.12	0.02~0.12	0.02~0.08
相配轴径 Mating Axis	硬度 HB Hardness	>220	>220	>220	>220	>220
	粗糙度 Ra Roughness	0.4~1.25	0.4~1.25	0.4~1.25	0.4~1.25	0.4~1.25
工作温度 °C Working temperature		-200~+280	-200~+280	-200~+280	-200~+280	-200~+280
导热系数 W/mk Thermal conductivity		40	60	40	40	40
线膨胀系数 (轴向) Coefficient of linear expansion		11 × 10 <sup>-6</sup> /K	18 × 10 <sup>-6</sup> /K	11 × 10 <sup>-6</sup> /K	11 × 10 <sup>-6</sup> /K	11 × 10 <sup>-6</sup> /K
表面镀层 Surface Plating		铜或锡 copper/tin	无 /No	铜或锡 copper/tin	无 /No	无 /No
针对性运用领域 Pertinence applicaton		产品应用于印刷机械、纺织机械、烟草机械、健身器等。 Application: the printing, woven, tobacco and gymnastic machinery, etc.	产品应用于冶金机械、连铸机械、水泥机械等。 Application: metallurgical industry, continuous casting and rolling mill, concrete machinery and spiral conveyers, etc.	该产品主要用于汽车减震器、摩托车减震器、液压油缸等。 Application: shock absorber of automobiles, motorcycles and pneumatic cylinder, etc.	该产品适用于食品饮料机械、化工泵阀、特药机械、印染机械、化工机械、海洋工业滑动部位等。 The product is suitable for food and beverage machinery, chemical pump valve, special medicine machinery, printing and dyeing machinery, chemical machinery, sliding parts of Marine industry, etc.	该产品适用于印染机械、海洋工业耐腐蚀部位等。 Application: the corrosion resistant part in dyeing machinery and ocean industry, etc.



## SF-1 轴套规格及公差 SF-1 Sleeve Bushing Specification & Tolerance

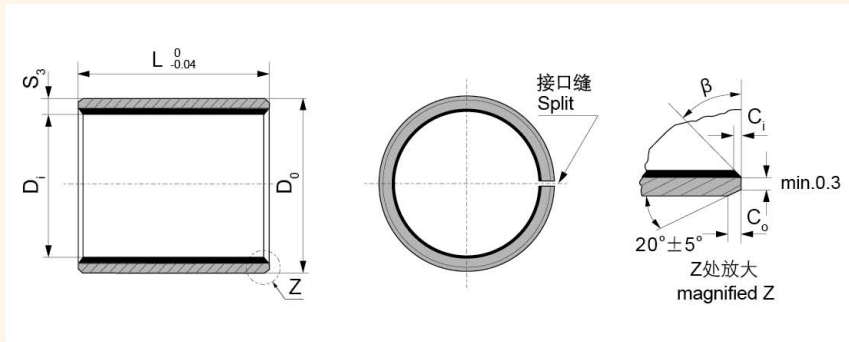

内外倒角 ID and OD chamfers

S <sub>3</sub>	C <sub>o</sub>	C <sub>i</sub>	β
0.75	0.5±0.3	0.25±0.2	35°±5°
1.00	0.6±0.3	0.30±0.2	35°±5°
1.50	0.7±0.3	0.50±0.3	35°±5°

S <sub>3</sub>	C <sub>o</sub>	C <sub>i</sub>	β
2.00	1.2±0.4	0.50±0.3	35°±5°
2.50	1.8±0.6	0.60±0.3	45°±5°

单位Unit: mm

轴径(f7) Shaft D <sub>s</sub>	座孔(H7) Housing D <sub>H</sub>	(OD) 外径公差 Tolerance D <sub>O</sub>	(ID)压装后 内孔公差 After fixed D <sub>int</sub>	配合间隙 Clearance D <sub>D</sub>	壁厚 Wall thick- ness S <sub>3</sub>	长度 L <sup>0</sup> <sub>-0.40</sub> (d≤Φ28 L-0.30 / d>Φ30 L-0.40)														
						6	8	10	12	15	20	25	30	40	50					
6	-0.010 -0.022	8	+0.015	8	+0.055 +0.025	6.055 5.990	0.077 0.000													
8	-0.013 -0.028	10	+0.015	10	+0.055 +0.025	8.055 7.990	0.083 0.003													
10	-0.013 -0.028	12	+0.018	12	+0.065 +0.030	10.058 9.990	0.086 0.003													
12	-0.016 -0.034	14	+0.018	14	+0.065 +0.030	12.058 11.990														
13	-0.016 -0.034	15	+0.018	15	+0.065 +0.030	13.058 12.990														
14	-0.016 -0.034	16	+0.018	16	+0.065 +0.030	14.058 13.990	0.092 0.006													
15	-0.016 -0.034	17	+0.018	17	+0.065 +0.030	15.058 14.990														
16	-0.016 -0.034	18	+0.018	18	+0.065 +0.030	16.058 15.990														
17	-0.016 -0.034	19	+0.021	19	+0.075 +0.035	17.061 16.990	0.095 0.006													
18	-0.016 -0.034	20	+0.021	20	+0.075 +0.035	18.061 17.990														
20	-0.020 -0.041	23	+0.021	23	+0.075 +0.035	20.071 19.990														
22	-0.020 -0.041	25	+0.021	25	+0.075 +0.035	22.071 21.990	0.112 0.010													
24	-0.020 -0.041	27	+0.021	27	+0.075 +0.035	24.071 23.990														
25	-0.020 -0.041	28	+0.021	28	+0.075 +0.035	25.071 24.990														
28	-0.020 -0.041	32	+0.025	32	+0.085 +0.045	28.085 27.990	0.126 0.010													
30	-0.020 -0.041	34	+0.025	34	+0.085 +0.045	30.085 29.990														
32	-0.025 -0.050	36	+0.025	36	+0.085 +0.045	32.085 31.990														
35	-0.025 -0.050	39	+0.025	39	+0.085 +0.045	35.085 34.990	0.135 0.015													
38	-0.025 -0.050	42	+0.025	42	+0.085 +0.045	38.085 37.990														
40	-0.025 -0.050	44	+0.025	44	+0.085 +0.045	40.085 39.990														

## SF-1 轴套规格及公差 SF-1 Sleeve Bushing Specification & Tolerance

轴径(f7) Shaft D <sub>s</sub>	座孔(H7) Housing D <sub>H</sub>	(OD) 外径公差 Tolerance D <sub>O</sub>	(ID)压装后 内孔公差 After fixed D <sub>i,a</sub>	配合间隙 Clearance D <sub>O</sub>	壁厚 Wall thick- ness S <sub>3</sub>	长度 L <sup>0</sup> <sub>-0.40</sub> ( d≤Φ28 L-0.30 d>Φ30 L-0.40 )												
						20	25	30	40	50	60	70	80	100	115			
45 -0.050 -0.025	50 +0.025	50 +0.085 +0.045	45.105 44.990	0.155 0.015	2.505 2.460	4520	4525	4530	4540	4550								
50 -0.050 -0.025	55 +0.030	55 +0.100 +0.055	50.110 49.990	0.160 0.015		5020	5025	5030	5040	5050	5060							
55 -0.060 -0.030	60 +0.030	60 +0.100 +0.055	55.110 54.990	0.170 0.020				5530	5540	5550	5560							
60 -0.060 -0.030	65 +0.030	65 +0.100 +0.055	60.110 59.990						6030	6040	6050	6060	6070					
65 -0.060 -0.030	70 +0.030	70 +0.100 +0.055	65.110 64.990						6530	6540	6550	6560	6570					
70 -0.060 -0.030	75 +0.030	75 +0.100 +0.055	70.110 69.990							7030	7040	7050	7060	7070	7080			
75 -0.060 -0.030	80 +0.030	80 +0.100 +0.055	75.110 74.990							7530	7540	7550	7560	7570	7580			
80 -0.045	85 +0.035	85 +0.120 +0.070	80.155 80.020	0.201 0.020	2.490 2.440				8040	8050	8060	8070	8080	80100				
85 -0.054	90 +0.035	90 +0.120 +0.070	85.155 85.020							8540	8550	8560	8570	8580	85100			
90 -0.054	95 +0.035	95 +0.120 +0.070	90.155 90.020	0.209 0.020					9040	9050	9060	9070	9080	90100				
95 -0.054	100 +0.035	100 +0.120 +0.070	95.155 95.020								9550	9560	9570	9580	95100			
100 -0.054	105 +0.035	105 +0.120 +0.070	100.155 100.020								10050	10060	10070	10080	100100	100115		
105 -0.054	110 +0.035	110 +0.120 +0.070	105.155 105.020									10560	10570	10580	105100	105115		
110 -0.054	115 +0.035	115 +0.120 +0.070	110.115 110.020										11060	11070	11080	110100	110115	
120 -0.054	125 +0.040	125 +0.170 +0.100	120.210 120.070	0.264 0.070	2.465 2.415						12060	12070	12080	120100	120115			
125 -0.063	130 +0.040	130 +0.170 +0.100	125.210 125.070									12560	12570	12580	125100	125115		
130 -0.063	135 +0.040	135 +0.170 +0.100	130.210 130.070	0.273 0.070								13060	13070	13080	130100	130115		
140 -0.063	145 +0.040	145 +0.170 +0.100	140.210 140.070										14060	14070	14080	140100	140115	
150 -0.063	155 +0.040	155 +0.170 +0.100	150.210 150.070										15060	15070	15080	150100	150115	
160 -0.063	165 +0.040	165 +0.170 +0.100	160.210 160.070										16060	16070	16080	160100	160115	
180 -0.063	185 +0.046	185 +0.210 +0.130	180.216 180.070			0.279 0.070	2.465 2.415						18060	18070	18080	180100		
190 -0.072	195 +0.046	195 +0.210 +0.130	190.216 190.070									19060	19070	19080	190100			
200 -0.072	205 +0.046	205 +0.210 +0.130	200.016 200.070	0.288 0.070								20060	20070	20080	200100			
220 -0.072	225 +0.046	225 +0.210 +0.130	220.216 220.070									22060	22070	22080	220100			
250 -0.072	255 +0.052	255 +0.260 +0.170	250.222 250.070	0.294 0.070	2.465 2.415										25080	250100		
260 -0.081	265 +0.052	265 +0.260 +0.170	260.222 260.070												26080	260100		
280 -0.081	285 +0.052	285 +0.260 +0.170	280.222 280.070	0.303 0.070											28080	280100		
300 -0.081	305 +0.052	305 +0.260 +0.170	300.222 300.070												30080	300100		

## SF-1F 翻边轴套规格及公差 SF-1F Flange Bushing Specification & Tolerance

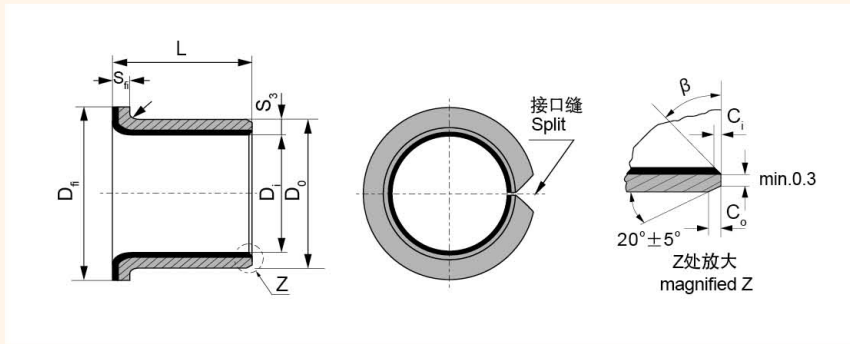

S <sub>3</sub>	1.0	1.5	2.0	2.5
r	1 <sup>-0.5</sup>	1±0.5	1.5±0.5	2±0.5

单位Unit: mm

Designation 型号规格	轴径(f7) Shaft D <sub>s</sub>	座孔(H7) Housing D <sub>H</sub>	(OD) 外径公差 Tolerance D <sub>o</sub>	(ID)压装后 内孔公差 After fixed D <sub>ia</sub>	配合间隙 Clearance C <sub>o</sub>	Wall thickness 壁厚 S <sub>3</sub>	尺寸 Dimension				
							D <sub>i</sub>	D <sub>o</sub>	D <sub>H</sub> ±0.5	L±0.25	S <sub>H</sub> ±0.2
SF-1F06040	6	8	8	6.055	0.077	1.005 0.980	6	8	12	4	1
SF-1F06070										7	
SF-1F08055	8	10	10	8.055	0.083		8	10	15	5.5	
SF-1F08075										7.5	
SF-1F10070	10	12	12	10.058	0.086		10	12	18	7	
SF-1F10090										9	
SF-1F10120										12	
SF-1F12070										7	
SF-1F12090	12	14	14	12.058	0.092		12	14	20	9	
SF-1F12120										12	
SF-1F14120										12	
SF-1F14170										17	
SF-1F15090	14	16	16	14.058	0.006		14	16	22	12	
SF-1F15120										12	
SF-1F15170										17	
SF-1F16120										12	
SF-1F16170	16	18	18	16.058	0.095		16	18	24	17	
SF-1F18120										12	
SF-1F18170										17	
SF-1F18200										20	
SF-1F20115	20	23	23	20.071	0.112	20	23	30	11.5		
SF-1F20165									16.5		
SF-1F20215									21.5		
SF-1F22150									15		
SF-1F22200	22	25	25	22.071	0.010	22	25	32	20		
SF-1F25115									11.5		
SF-1F25165									16.5		
SF-1F25215									21.5		
SF-1F30160	30	34	34	30.085	0.126	30	34	42	16		
SF-1F30260									26		
SF-1F35160	35	39	39	35.085	0.135	35	39	47	16		
SF-1F35260									26		
SF-1F40260									26		
SF-1F40400									40		

## SF-1WC 垫片规格及公差 SF-1WC Thrust Washer Specification & Tolerance

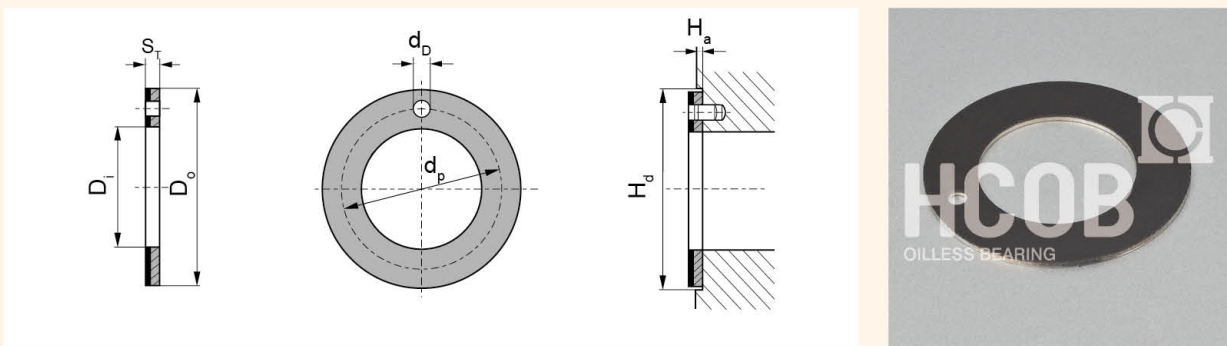

单位Unit: mm

型号规格 Standard No.	轴径 Shaft $D_s$	垫片尺寸 Washer size				安装尺寸 Assemble size		
		$D_i+0.25$	$D_o-0.25$	$S_r-0.05$	$d_p \pm 0.125$	$d_o^{+0.4}_{+0.1}$	$H_a \pm 0.2$	$H_o + 0.12$
W10	8	10	20	1.5	15	1.5	1	20
W12	10	12	24		18			24
W14	12	14	26		20			26
W16	14	16	30		23			30
W18	16	18	32		25	32		
W20	18	20	36		28	36		
W22	20	22	38		30	3		38
W24	22	24	42		33			42
W26	24	26	44		35			44
W28	26	28	48		38			48
W32	30	32	54	43	4	54		
W38	36	38	62	50		62		
W42	40	42	66	54		66		
W48	46	48	74	61		74		
W52	50	52	78	65		1.5	78	
W62	60	62	90	76			90	

## SF-1SP 板材标准公制尺寸 SF-1SP Strip Standard Metric Size

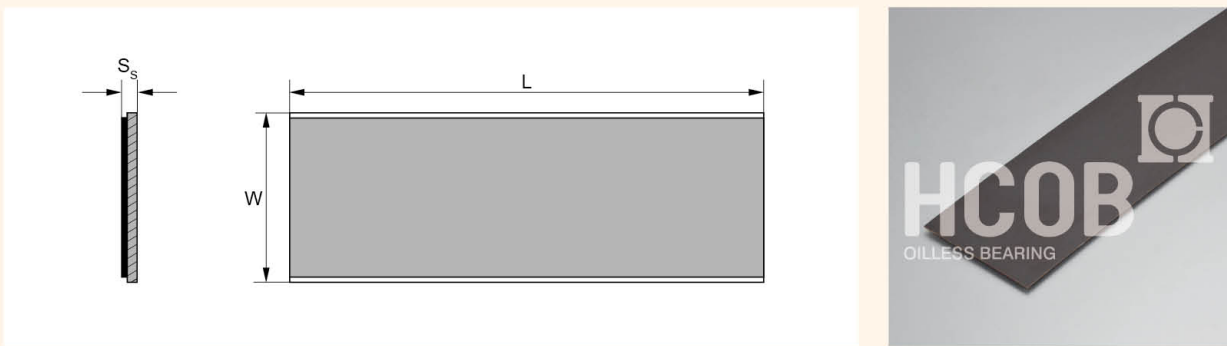

单位Unit: mm

型号规格 Standard No.	长度 $L \pm 1$	宽度 $W \pm 1$	厚壁 Wall thickness $S_s - 0.05$
SP	500	150	1.0
SP	500	150	1.5
SP	500	150	2.0
SP	500	150	2.5

## SF-2 金属塑料边界润滑轴承 SF-2 Metal-polymer marginal lubricating bearings



### 结构特性 Structure Characteristics

SF-2 金属复合边界润滑材料以优质低碳钢为基板，中间烧结球形多孔铜粉层，表面轧制以改性聚甲醛 (POM) 或聚醚醚酮 (PEEK) 为主的耐磨润滑材料作为轴承工作层，表面规则的油穴不但可以储存油脂，而且可以有效埋没外部入侵的粉尘，提高了轴承的使用寿命。这种材料具有优异的机械承载能力，中间铜粉层不但可以及时传递轴承运行过程中产生的热量，同时也提高了塑料层与基板的结合强度。以 POM 或 PEEK 为主的表面耐磨材料设计适用于油脂润滑工况，轴承表面有规律地排列着用于储存油脂的油穴以保证润滑剂在整个轴承表面的最佳分布。

SF-2 Metal-polymer marginal lubricating composite materials consist of metal backing sintered porous bronze with POM or PEEK polymer as working layer. Steel backing provides exceptionally high load carrying capacity, excellent heat dissipation. Sintered bronze powder provides thermal conductivity away from the bearing surface, also serves as a reservoir for the resin mixture. And the POM or PEEK polymer layer provides high wear resistance and low friction even with only minute volume of lubricant are supplied, this bearing surface carries a pattern of circular indents which should be filled with grease on assembly of the bearing.





### 产品应用 Application

产品广泛应用于：  
汽车工业：踏板总成、平衡轴套、制动钳、转向主销轴套和卡车尾板轴套等；  
物流机械：搬运车、起重机、车载吊车、森林机械、包装机械等；  
以及液压马达、液压油缸、气动元件、农用机械等。

Recommended for applications involving intermittent operation or boundary lubrication...  
Automotive: Pedal assembly, Balance shaft sleeve, Steering king pin shaft sleeve...  
Logistics machine: carrier, chain block, Car crane, packaging machine....And hydraulic motor,Hydraulic cylinders, pneumatic element, agricultural machine...

实际运用中根据使用环境、工况和环保要求的不同，表面塑料层 POM/PEEK 里可以添加不同的填充材料。产品范围包括: SF-2 (黑)、SF-2Y (黄)、SF-2H (红)、SF-2L (蓝)、SF-2P (PEEK)。

According to the different working conditions and environmental protection, the POM or PEEK layer with different polymer filler, Surface tin or copper plating. product range includes SF-2(Black)、SF-2Y(Yellow)、SF-2H(Red)、SF-2L(Blue)、SF-2P(PEEK).

有关数据 Data	代号 Grade	SF-2 (黑) (Lead free)	SF-2Y (黄) (Lead free)	SF-2H (红) (Lead free)	SF-2L (蓝) (Lead free)	SF-2P (黑) (Without lead)
	材料 Material	碳钢/Steel+铜粉/ Bronze+(POM+Pb)	碳钢/Steel+铜粉/ Bronze+POM	碳钢/Steel+铜粉/ Bronze+POM	碳钢/Steel+铜粉/ Bronze+POM	碳钢/Steel+铜粉/ Bronze+(PTFE+PEEK)
除了目录中显示的标准产品外，还可以提供非标产品或根据客户要求订购。 We can also develop according to customers special request while out of this table.						
最大承载压力P Max load capacity P	静载 N/mm <sup>2</sup> Static load	140	140	110	140	140
	动载 N/mm <sup>2</sup> Dynamic load	70	70	45	70	100
最大线速度 V m/s Max line speed V		2.5	2.5	2.5	2.5	2.5
最高PV值 N/mm <sup>2</sup> ·m/s PV value limit	脂润滑 Greases lubrication	2.8	2.8	2.8	2.8	2.5
摩擦系数u Friction coef u		0.06~0.12	0.06~0.12	0.05~0.1	0.06~0.12	0.08~0.12
相配轴径 Mating Axis	硬度 HB Hardness	>270	>270	>270	>270	>270
	粗糙度 Ra Roughness	0.4~1.25	0.4~1.25	0.4~1.25	0.4~1.25	0.4~1.25
工作温度 °C Working temperature		-40~+120	-40~+120	-60~+120	-60~+120	-150~+250
导热系数 W/mk Thermal conductivity		52	52	52	52	52
线膨胀系数 (轴向) Coefficient of linear xpansion		11 × 10 <sup>-6</sup> /K	11 × 10 <sup>-6</sup> /K	11 × 10 <sup>-6</sup> /K	11 × 10 <sup>-6</sup> /K	11 × 10 <sup>-6</sup> /K
针对性运用领域 Pertinence applicaton		产品应用于汽车底盘、锻压机床、冶金机械、矿山机械、水利行业、轧钢行业等。 It's used in vehicle chassis, forming machine tools, steel metallurgical machinery, mineral mountain machinery, hydraulic industry and rolling steel industry, etc.				产品应用于锻压机床、冶金机械、矿山机械、液压马达等高端应用。 The product is applied in forging press, metallurgy machine, mine machine, irrigation industry, hydraulic moto high-end application, etc.

## SF-2 轴承规格及公差 SF-2 Sleeve Bushing Specification & Tolerance

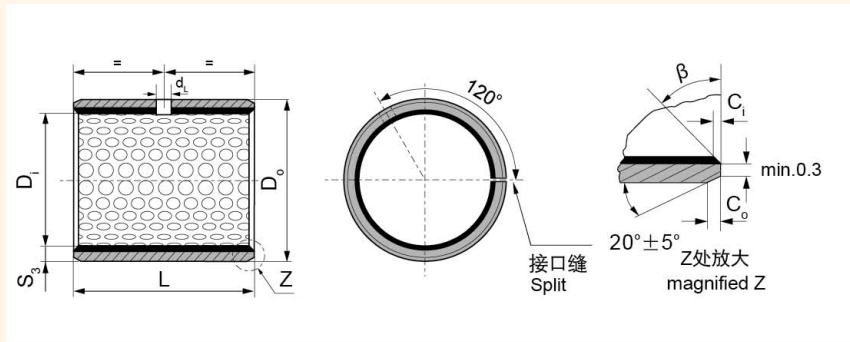

内外倒角 ID and OD chamfers

S <sub>3</sub>	C <sub>o</sub>	C <sub>i</sub>	β	S <sub>3</sub>	C <sub>o</sub>	C <sub>i</sub>	β
1.0	0.6±0.3	0.30±0.2	30°±5°	2.00	1.2±0.4	0.50±0.3	30°±5°
1.5	0.7±0.3	0.50±0.2	30°±5°	2.50	1.8±0.6	0.80±0.3	45°±5°

单位Unit: mm

轴径 Shaft D <sub>s</sub> h8	座孔 Housing H7 D <sub>H</sub>	(OD) 外径公差 Tolerance D <sub>o</sub>	(ID)压装后 内孔公差 After fixed D <sub>i,a</sub>	配合间隙 Clearance D <sub>o</sub>	壁厚 Wall thick- ness S <sub>3</sub>	油孔 Oil hole d <sub>L</sub>	长度 L <sub>0</sub> <sup>0</sup> <sub>-0.40</sub>														
							10	15	20	25	30	35	40	45	50	60					
10	-0.022	12 <sup>+0.018</sup>	12 <sup>+0.065</sup> 12 <sup>+0.030</sup>	10.108 10.040	0.130 0.040	4	1010	1015	1020												
12	-0.027	14 <sup>+0.018</sup>	14 <sup>+0.065</sup> 14 <sup>+0.030</sup>	12.108 12.040	0.135 0.040		1210	1215	1220												
14	-0.027	16 <sup>+0.018</sup>	16 <sup>+0.065</sup> 16 <sup>+0.030</sup>	14.108 14.040			1415	1420													
15	-0.027	17 <sup>+0.018</sup>	17 <sup>+0.065</sup> 17 <sup>+0.030</sup>	15.108 15.040			1515	1520	1525												
16	-0.027	18 <sup>+0.018</sup>	18 <sup>+0.065</sup> 18 <sup>+0.030</sup>	16.108 16.040			1615	1620	1625												
18	-0.027	20 <sup>+0.021</sup>	20 <sup>+0.075</sup> 20 <sup>+0.035</sup>	18.111 18.040			0.138 0.040	1815	1820	1825											
20	-0.033	23 <sup>+0.021</sup>	23 <sup>+0.075</sup> 23 <sup>+0.035</sup>	20.131 20.050			0.164 0.050	2015	2020	2025	2030										
22	-0.033	25 <sup>+0.021</sup>	25 <sup>+0.075</sup> 25 <sup>+0.035</sup>	22.131 22.050	2215	2220		2225	2230												
25	-0.033	28 <sup>+0.021</sup>	28 <sup>+0.075</sup> 28 <sup>+0.035</sup>	25.131 25.050	0.188 0.060	6	2515	2520	2525	2530											
28	-0.033	32 <sup>+0.025</sup>	32 <sup>+0.085</sup> 32 <sup>+0.045</sup>	28.155 28.060			2820	2825	2830												
30	-0.033	34 <sup>+0.025</sup>	34 <sup>+0.085</sup> 34 <sup>+0.045</sup>	30.155 30.060			3020	3025	3030	3035	3040										
35	-0.039	39 <sup>+0.025</sup>	39 <sup>+0.085</sup> 39 <sup>+0.045</sup>	35.155 35.060	0.194 0.060	3520	3525	3530	3535	3540											
40	-0.039	44 <sup>+0.025</sup>	44 <sup>+0.085</sup> 44 <sup>+0.045</sup>	40.155 40.060		4020	4025	4030	4035	4040	4045	4050									
45	-0.039	50 <sup>+0.025</sup>	50 <sup>+0.085</sup> 50 <sup>+0.045</sup>	45.195 45.080	0.234 0.080	8	4520	4525	4530	4535	4540	4545	4550								
50	-0.039	55 <sup>+0.030</sup>	55 <sup>+0.100</sup> 55 <sup>+0.055</sup>	50.200 50.080			5030	5035	5040	5045	5050	5060									
55	-0.046	60 <sup>+0.030</sup>	60 <sup>+0.100</sup> 60 <sup>+0.055</sup>	55.200 55.080			5530	5535	5540	5545	5550	5560									
60	-0.046	65 <sup>+0.030</sup>	65 <sup>+0.100</sup> 65 <sup>+0.055</sup>	60.200 60.080	0.246 0.080	6030	6035	6040	6045	6050	6060										

## SF-2 轴承规格及公差 SF-2 Sleeve Bushing Specification & Tolerance

轴径 Shaft D <sub>s</sub> h8	座孔 Housing H7 D <sub>H</sub>	(OD) 外径公差 Tolerance D <sub>o</sub>	(ID)压装后 内孔公差 After fixed D <sub>ia</sub>	配合间隙 Clearance D <sub>D</sub>	壁厚 Wall thick- ness S <sub>2</sub>	油孔 Oil hole d <sub>L</sub>	长度 L <sup>0</sup> <sub>-0.40</sub>												
							40	50	60	80	90	95	100	110	120				
65 <sub>-0.046</sub>	70 <sup>+0.030</sup>	70 <sup>+0.100</sup> <sub>+0.055</sub>	65.200 65.080	0.246 0.080	2.460 2.415	8	6540	6550	6560										
70 <sub>-0.046</sub>	75 <sup>+0.030</sup>	75 <sup>+0.100</sup> <sub>+0.055</sub>	70.200 70.080				7040	7050	7060	7080									
75 <sub>-0.046</sub>	80 <sup>+0.030</sup>	80 <sup>+0.100</sup> <sub>+0.055</sub>	75.200 75.080				7540	7550	7560	7580									
80 <sub>-0.046</sub>	85 <sup>+0.035</sup>	85 <sup>+0.120</sup> <sub>+0.070</sub>	80.265 80.100	0.313 0.100			8040	8050	8060	8080									
85 <sub>-0.054</sub>	90 <sup>+0.035</sup>	90 <sup>+0.120</sup> <sub>+0.070</sub>	85.265 85.100				8540	8550	8560	8580									
90 <sub>-0.054</sub>	95 <sup>+0.035</sup>	95 <sup>+0.120</sup> <sub>+0.070</sub>	90.265 90.100				9040	9050	9060	9080	9090								
100 <sub>-0.054</sub>	105 <sup>+0.035</sup>	105 <sup>+0.120</sup> <sub>+0.070</sub>	100.265 100.100	0.321 0.100				10050	10060	10080	10090	10095							
105 <sub>-0.054</sub>	110 <sup>+0.035</sup>	110 <sup>+0.120</sup> <sub>+0.070</sub>	105.265 105.100				10550	10560	10580	10590	10595	105100	105110						
110 <sub>-0.054</sub>	115 <sup>+0.035</sup>	115 <sup>+0.120</sup> <sub>+0.070</sub>	110.265 110.110				11050	11060	11080	11090	11095	110100	110110						
120 <sub>-0.054</sub>	125 <sup>+0.040</sup>	125 <sup>+0.170</sup> <sub>+0.100</sub>	120.270 120.110	0.324 0.100				12050	12060	12080	12090	12095	120100	120110					
125 <sub>-0.063</sub>	130 <sup>+0.040</sup>	130 <sup>+0.170</sup> <sub>+0.100</sub>	125.270 125.110				12550	12560	12580	12590	12595	125100	125110						
130 <sub>-0.063</sub>	135 <sup>+0.040</sup>	135 <sup>+0.170</sup> <sub>+0.100</sub>	130.270 130.110				13050	13060	13080	13090	13095	130100	130110						
140 <sub>-0.063</sub>	145 <sup>+0.040</sup>	145 <sup>+0.170</sup> <sub>+0.100</sub>	140.270 140.110	0.324 0.100				14050	14060	14080	14090	14095	140100	140110					
150 <sub>-0.063</sub>	155 <sup>+0.040</sup>	155 <sup>+0.170</sup> <sub>+0.100</sub>	150.270 150.110				15050	15060	15080	15090	15095	150100	150110						
160 <sub>-0.063</sub>	165 <sup>+0.040</sup>	165 <sup>+0.170</sup> <sub>+0.100</sub>	160.270 160.110				16050	16060	16080	16090	16095	160100	160110						
170 <sub>-0.063</sub>	175 <sup>+0.040</sup>	175 <sup>+0.170</sup> <sub>+0.100</sub>	170.270 170.110	0.339 0.110				17050	17060	17080	17090	17095	170100	170110					
180 <sub>-0.063</sub>	185 <sup>+0.046</sup>	185 <sup>+0.210</sup> <sub>+0.130</sub>	180.276 180.110				18050	18060	18080	18090	18095	180100	180110						
190 <sub>-0.072</sub>	195 <sup>+0.046</sup>	195 <sup>+0.210</sup> <sub>+0.130</sub>	190.276 190.110				19050	19060	19080	19090	19095	190100	190110	190120					
200 <sub>-0.072</sub>	205 <sup>+0.046</sup>	205 <sup>+0.210</sup> <sub>+0.130</sub>	200.276 200.110	0.339 0.110				20050	20060	20080	20090	20095	200100	200110	200120				
220 <sub>-0.072</sub>	225 <sup>+0.046</sup>	225 <sup>+0.210</sup> <sub>+0.130</sub>	220.276 220.110				22050	22060	22080	22090	22095	220100	220110	220120					
240 <sub>-0.072</sub>	245 <sup>+0.046</sup>	245 <sup>+0.210</sup> <sub>+0.130</sub>	240.276 240.110				24050	24060	24080	24090	24095	240100	240110	240120					
250 <sub>-0.072</sub>	255 <sup>+0.052</sup>	255 <sup>+0.260</sup> <sub>+0.170</sub>	250.282 250.110	0.354 0.110				25050	25060	25080	25090	25095	250100	250110	250120				
260 <sub>-0.081</sub>	265 <sup>+0.052</sup>	265 <sup>+0.260</sup> <sub>+0.170</sub>	260.282 260.110				26050	26060	26080	26090	26095	260100	260110	260120					
280 <sub>-0.081</sub>	285 <sup>+0.052</sup>	285 <sup>+0.260</sup> <sub>+0.170</sub>	280.282 280.110				28050	28060	28080	28090	28095	280100	280110	280120					
300 <sub>-0.081</sub>	305 <sup>+0.052</sup>	305 <sup>+0.260</sup> <sub>+0.170</sub>	300.282 300.110					30050	30060	30080	30090	30095	300100	300110	300120				



### SF-2WC 垫片规格及公差 SF-2WC Thrust Washer Specification & Tolerance

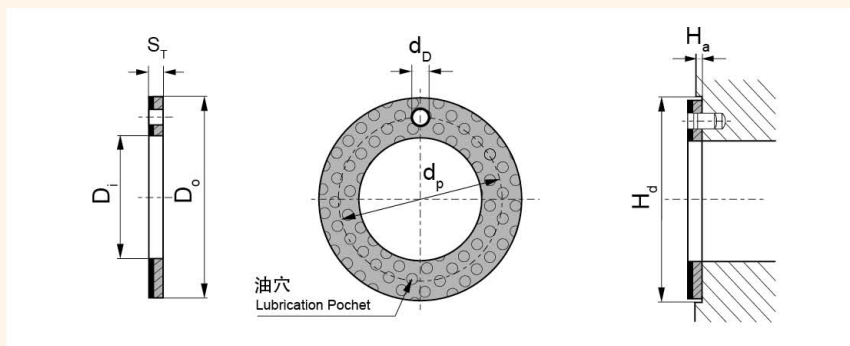

单位Unit: mm

型号规格 Standard No.	轴径 Shaft $D_s$	垫片尺寸 Washer size				安装尺寸 Assemble size		
		$D_i+0.25$	$D_o-0.25$	$S_T-0.05$	$d_p \pm 0.125$	$d_{D+0.1}^{+0.4}$	$H_a \pm 0.2$	$H_a+0.12$
W10	8	10	20		15	1.5	1	20
W12	10	12	24		18			24
W14	12	14	26		20			26
W16	14	16	30		23			30
W18	16	18	32		25	2	1.5	32
W20	18	20	36		28			36
W22	20	22	38	1.5	30			38
W24	22	24	42		33			42
W26	24	26	44		35	3	1	44
W28	26	28	48		38			48
W32	30	32	54		43			54
W38	36	38	62		50			62
W42	40	42	66		54	4	1.5	66
W48	46	48	74		61			74
W52	50	52	78	2	65			78
W62	60	62	90		76			90

### SF-2SP 板材标准公制尺寸 SF-2SP Strip Standard Metric Size

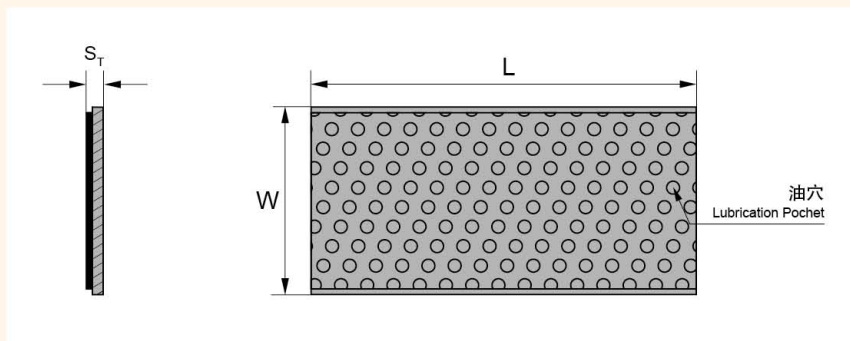

单位Unit: mm

型号规格 Standard No.	长度 $L \pm 1$	宽度 $W \pm 1$	厚壁 Wall thickness $S_s -0.05$
SP	500	150	1.0
SP	500	150	1.5
SP	500	150	2.0
SP	500	150	2.5

## JF-800 双金属复合轴承 JF-800 Bi-metallic composite bearings



### 结构特性 Structure Characteristics

JF-800 双金属复合轴承以优质低碳钢为基体，表面烧结具有低摩擦特性的铜合金（CuPb10Sn10、CuPb6Sn6Zn3、CuPb24Sn4、CuPb30、AlSn20Cu、CuSn8Ni）作为轴承的耐磨层，铜合金表面可以根据使用工况需要加工出各种类型的油槽、油孔、油穴等，以适合于无法持续加油或者难以加油的场合。材料通过二次烧结二次挤压可以得到很好的接合强度和最佳的承载能力。

JF-800 Bi-metallic composite bearing material consists of steel backing with lead bronze or lead-free copper alloy (CuPb10Sn10, CuPb6Sn6Zn3, CuPb24Sn4, CuPb30, AlSn20Cu) lining, bearing material for oil/grease lubricated applications. The copper alloy forms a continuously frame for thermal conductivity. These bearing structures are with high load capacity and good fatigue property. Higher tolerance can be achieved after re-machined from the customers. Lead-free bronze lining bearing material conforms to the European RoHS directive.

### 产品应用 Application







工程机械：底盘行走机构支重轮轴套、拖带轮轴套、张紧轮轴套；  
汽车行业：平衡轴衬套、钢板销衬套、转向节主肖轴套、连杆轴套、气门摇臂轴套、凸轮轴轴套、差速器轴套、变速箱轴套、内燃机主轴瓦、止推垫片；以及柱塞泵侧片，齿轮泵侧片等。

Engineering machine: underpan, thrust wheel, Towing wheel, Steering knuckle, tension pulley...

Automotive: trunnion shaft, connecting rod, valve rocker, camshaft, gear box, internal-combustion engine, and Plunger pump friction plate, gear pump friction plate...

实际运用中根据使用工况的不同，表面可以烧结不同牌号的合金，产品范围包括：JF-820、JF-800、JF-720、JF-700、JF-20、FB08G。

According to the different working conditions, different alloy material (CuPb10Sn10、CuPb6Sn6Zn3、CuPb24Sn4、CuPb30、AlSn20Cu、CuSn8Ni) can be sintered on steel backing. product range includes JF-820、JF-800、JF-720、JF-700、JF-20、FB08G.

有关数据 Data	代号 Grade	JF-820 (lead free)	JF-800	JF-720	JF-700	JF-20	FB08G
	材料 Material	碳钢/Steel + CuSn8Ni	碳钢/Steel + CuPb <sub>10</sub> Sn <sub>10</sub>	碳钢/Steel + CuPb <sub>24</sub> Sn <sub>4</sub>	碳钢/Steel + CuPb <sub>30</sub>	碳钢/Steel + AlSn <sub>20</sub> Cu	碳钢/Steel + CuPb <sub>10</sub> Sn <sub>10</sub> +石墨/Graphite
除了目录中显示的标准产品外，还可以提供非标产品或根据客户要求订购。 We can also develop according to customers special request while out of this table.							
最大动载 P N/mm <sup>2</sup> Max dynamic Load P		140	140	140	120	120	90
最大线速度 V m/s Max line speed V	脂润滑 Greases lubrication	2.5	2.5	2.5	2.5	—	—
最高PV值 N/mm <sup>2</sup> ·m/s Max PV value		2.8	2.8	2.8	2.8	—	—
摩擦系数 u Friction coef u		0.05~0.12	0.05~0.15	0.05~0.15	0.05~0.15	—	—
最大线速度 V m/s Max line speed V		2.5	10	10	15	20	—
最高PV值 N/mm <sup>2</sup> ·m/s Max PV value	油脂润滑 Greases lubrication	2.8	10	10	8	15	—
摩擦系数 Friction	油润滑 Oil lub.	0.04~0.12	0.04~0.12	0.04~0.12	0.04~0.12	0.04~0.12	—
最高温度 °C Max Working temperature	油脂润滑 Greases lubrication	150	150	150	150	150	150
	油润滑 Oil lub.	250	250	250	250	250	—
相配轴径 Mating Axis	硬度 HRC Hardness	≥53	≥53	≥45	≥48	≥270	≥53
	粗糙度 Ra Roughness	0.32~0.63	0.32~0.63	0.32~0.63	0.16~0.63	0.16~0.63	0.16~0.63
合金层硬度 HB Alloy layer hardness		69~90	70~100	45~70	35~45	30~40	60~90
导热系数 W/mk Thermal conductivity		47	47	60	60	47	47
线膨胀系数 (轴向) Coefficient of linear expansion		18×10 <sup>-6</sup> /K	18×10 <sup>-6</sup> /K	18×10 <sup>-6</sup> /K	19×10 <sup>-6</sup> /K	19×10 <sup>-6</sup> /K	18×10 <sup>-6</sup> /K
针对性运用领域 Pertinence applicator		适用于中等负载，以及有大的冲击载荷的轴承，如发动机连杆轴套、转向销轴套等。 Lead free, For use in medium load conditions, such as the engine connecting rod bushings, steering pin covers.	产品适用于汽车发动机连杆，工程机械、农业机械等。 Application: con-rod of automobile engines, engineering and agriculture machinery, heavy duty construction machinery etc.	产品适用于高速、重载的内燃机主轴和变速齿轮。 Application: High speed, heavy load engine main shaft and transmission gearbox, etc.	用作高速、中低载荷的内燃机主瓦、连杆衬套、摇臂衬套、油汞侧摩擦片。 high speed and middle load working situation, as engine main bearing, connect-rod bushing, rocket arm bushing and oil pump side plate.	产品适用于内燃机主轴和连杆轴承、空压机、制冷机用轴承。 Application: High speed, heavy load engine main shaft and air compressor, cooling machine etc.	产品适用于启动马达机械。 Application: starting motor.

**JF-800 双金属复合轴承**  
**JF-800 Bi-metallic composite bearings**

**双金属自润滑轴承的油槽油穴形式 Type for Bi-Metallic Bushing Grooves and Indents**

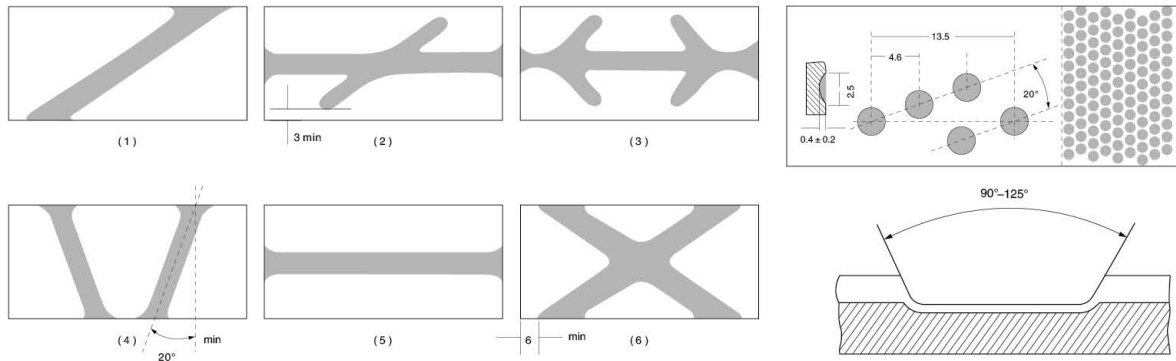

**双金属轴承的搭扣形式 Lock Types for Bi-Metallic Bushing**

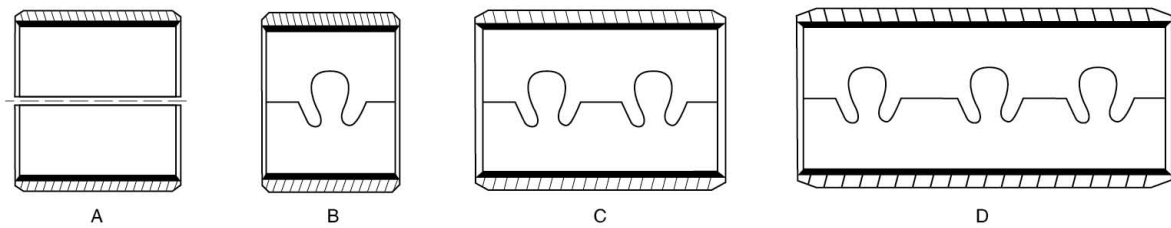

**材料特性 Material Characterisitc**

材料牌号 Material Trademark	合金成份 Alloy Composition	合金硬度 Alloy Hardness	国际标准 International Standard
<b>JF-800</b>	CuPb10Sn10	70~100HB	SAE-797. DIN CuPb10Sn. JIS-LBC3. UNS C93700. Clevite F100. Daido L10. D. A. B. D57. Federal Mogul HF2. Glacier SY. Glyco66. Miba2. 1010. Taiho HF2. Kar I Schmiat KS940SSAE-797. DIN CuPb10Sn. JIS-LBC3. UNS C93700. Clevite F100. Daido L10. D. A. B D57. Federal Mogul HF2 Glacier SY. Glyco66. Miba2. 1010. Taiho HF2. Karl Schmiat Ks940s
<b>JF-720</b>	CuPb24Sn4	45~70HB	SAE=799. GLYCO 68. JIS-LBC6. DAIDO L23. Claciersx. ACLF250
<b>JF-700</b>	CuPb30	30~45HB	SAE-783. GLYCO74. JIS-AJL
<b>JF-20</b>	AlSn20Cu	30~40HB	SAE-48. JIS-KJ3
<b>JF-820</b>	CuSn8Ni	69~90HB	

## JF-800 双金属轴承规格及公差 JF-800 Bimetal Sleeve Bushing Specification & Tolerance

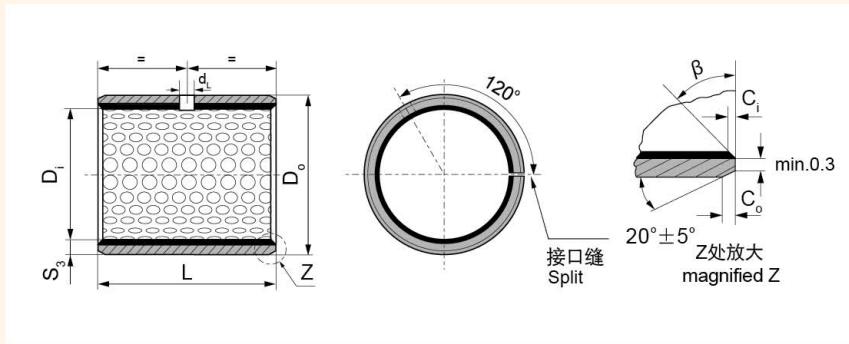

内外倒角 ID and OD chamfers

S <sub>3</sub>	C <sub>o</sub>	C <sub>i</sub>	β
0.75	0.5±0.3	0.25±0.2	35°±5°
1.00	0.6±0.3	0.30±0.2	35°±5°
1.50	0.7±0.3	0.50±0.3	35°±5°

S <sub>3</sub>	C <sub>o</sub>	C <sub>i</sub>	β
2.00	1.2±0.4	0.50±0.3	35°±5°
2.50	1.8±0.6	0.60±0.3	45°±5°

单位unit:mm

内径 D <sub>i</sub> φd	外径 D <sub>o</sub> φD	轴径(h8) Shaft D <sub>s</sub>	座孔(H7) Housing D <sub>H</sub>	压装后 内孔公差 Arter fixed D <sub>ia</sub>	配合间隙 Clearance C <sub>D</sub>	壁厚 Wall thickness S <sub>3</sub>	油孔 Oil hole d <sub>L</sub>	长度 L <sup>0</sup> <sub>-0.40</sub>							
								10	15	20	25	30	40	50	
10	12	10 <sup>-0.022</sup>	12 <sup>+0.018</sup>		0.170 0.010			1010	1015	1020					
12	14	12 <sup>-0.027</sup>	14 <sup>+0.018</sup>					1210	1215	1220					
14	16	14 <sup>-0.027</sup>	16 <sup>+0.018</sup>	+0.148 +0.010	0.175 0.010	0.995 0.935	4	1410	1415	1420					
15	17	15 <sup>-0.027</sup>	17 <sup>+0.018</sup>					1510	1515	1520					
16	18	16 <sup>-0.027</sup>	18 <sup>+0.018</sup>					1610	1615	1620					
18	20	18 <sup>-0.027</sup>	20 <sup>+0.021</sup>	+0.151 +0.010	0.178 0.010			1810	1815	1820	1825				
20	23	20 <sup>-0.033</sup>	23 <sup>+0.021</sup>					2010	2015	2020	2025				
22	25	22 <sup>-0.033</sup>	25 <sup>+0.021</sup>	+0.161 +0.020	0.194 0.020	1.490 1.430		2210	2215	2220	2225				
24	27	24 <sup>-0.033</sup>	27 <sup>+0.021</sup>					2410	2415	2420	2425	2430			
25	28	25 <sup>-0.033</sup>	28 <sup>+0.021</sup>					2515	2520	2525	2530				
26	30	26 <sup>-0.033</sup>	30 <sup>+0.021</sup>	+0.181 +0.040	0.214 0.040		6	2615	2620	2625	2630				
28	32	28 <sup>-0.033</sup>	32 <sup>+0.025</sup>		0.218 0.040			2815	2820	2825	2830	2840			
30	34	30 <sup>-0.033</sup>	34 <sup>+0.025</sup>					3015	3020	3025	3030	3040			
32	36	32 <sup>-0.039</sup>	36 <sup>+0.025</sup>	+0.185 +0.040		1.980 1.920		3215	3220	3225	3230	3240			
35	39	35 <sup>-0.039</sup>	39 <sup>+0.025</sup>		0.224 0.040				3520	3525	3530	3540	3550		
38	42	38 <sup>-0.039</sup>	42 <sup>+0.025</sup>				8		3820	3825	3830	3840	3850		
40	44	40 <sup>-0.039</sup>	44 <sup>+0.025</sup>						4020	4025	4030	4040	4050		

## JF-800 双金属轴承规格及公差 JF-800 Bimetal Sleeve Bushing Specification & Tolerance

内径 D <sub>i</sub> φd	外径 D <sub>o</sub> φD	轴径(h8) Shaft D <sub>s</sub>	座孔(H7) Housing D <sub>H</sub>	压装后 内孔公差 Arter fixed D <sub>ia</sub>	配合间隙 Clearance C <sub>D</sub>	壁厚 Wall thickness S <sub>s</sub>	油孔 Oil hole d <sub>L</sub>	长度 L <sup>0</sup> <sub>-0.40</sub>											
								25	30	40	50	60	80	90	100				
45	50	45 <sup>-0.039</sup>	50 <sup>+0.025</sup>	+0.225 +0.080	0.264 0.080	2.460 2.400	8	4525	4530	4540	4550								
50	55	50 <sup>-0.039</sup>	55 <sup>+0.030</sup>	+0.230 +0.080	0.269 0.080					5030	5040	5050	5060						
55	60	55 <sup>-0.046</sup>	60 <sup>+0.030</sup>								5530	5540	5550	5560					
60	65	60 <sup>-0.046</sup>	65 <sup>+0.030</sup>								6030	6040	6050	6060					
65	70	65 <sup>-0.046</sup>	70 <sup>+0.030</sup>					0.276 0.080			6530	6540	6550	6560					
70	75	70 <sup>-0.046</sup>	75 <sup>+0.030</sup>								7030	7040	7050	7060	7080				
75	80	75 <sup>-0.046</sup>	80 <sup>+0.030</sup>								7530	7540	7550	7560	7580				
80	85	80 <sup>-0.046</sup>	85 <sup>+0.035</sup>	+0.235 +0.080	0.281 0.080					8030	8040	8050	8060	8080	8090				
85	90	85 <sup>-0.054</sup>	90 <sup>+0.035</sup>								8530	8540	8550	8560	8580	8590	85100		
90	95	90 <sup>-0.054</sup>	95 <sup>+0.035</sup>										9040	9050	9060	9080	9090	90100	
95	100	95 <sup>-0.054</sup>	100 <sup>+0.035</sup>											9550	9560	9580	9590	95100	
100	105	100 <sup>-0.054</sup>	105 <sup>+0.035</sup>					0.289 0.080						10050	10060	10080	10090	100100	
105	110	105 <sup>-0.054</sup>	110 <sup>+0.035</sup>											10550	10560	10580	10590	105100	
110	115	110 <sup>-0.054</sup>	115 <sup>+0.035</sup>							9.5				11050	11060	11080	11090	110100	
115	120	115 <sup>-0.054</sup>	120 <sup>+0.035</sup>									11550	11560	11580	11590	115100			
120	125	120 <sup>-0.054</sup>	125 <sup>+0.040</sup>		+0.240 +0.080	0.303 0.080						12050	12060	12080	12090	120100			
125	130	125 <sup>-0.063</sup>	130 <sup>+0.040</sup>											12560	12580	12590	125100		
130	135	130 <sup>-0.063</sup>	135 <sup>+0.040</sup>										13060	13080	13090	130100			
135	140	135 <sup>-0.063</sup>	140 <sup>+0.040</sup>										13560	13580	13590	135100			
140	145	140 <sup>-0.063</sup>	145 <sup>+0.040</sup>										14060	14080	14090	140100			
150	155	150 <sup>-0.063</sup>	155 <sup>+0.040</sup>										15060	15080	15090	150100			

## JF-800F 双金属翻边轴承规格及公差 JF-800F Bimetal Flange Bushing Specification & Tolerance

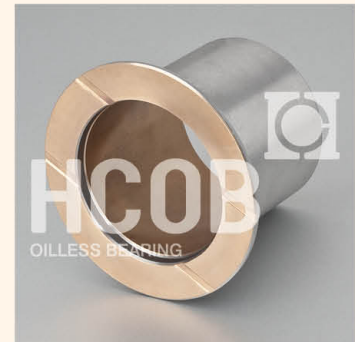
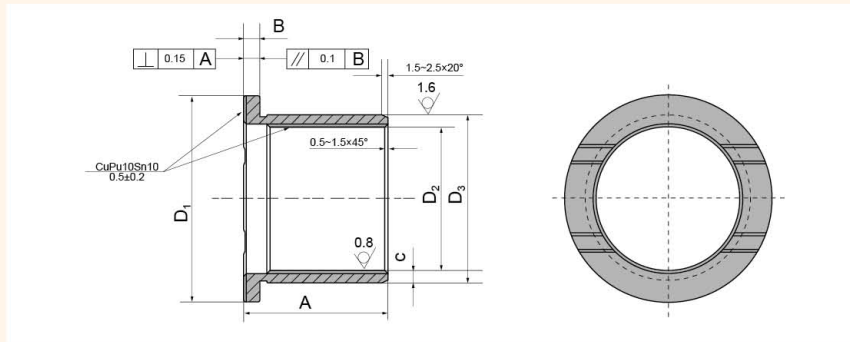

单位 Unit: mm

D <sub>1</sub>	B	D <sub>3</sub>	D <sub>2</sub>	A	C
42	3.5	37	30	30	3.5
43	2	34	30	28	2
44	3.5	39	32	35	3.5
47	3.5	39	32	50	3.5
48	2	39	35	37	2
52	3	41	35	35	3
55	3.5	42	35	35	3.5
55	3.5	45	38	35	3.5
55	3.5	45	38	40	3.5
60	3	41	35	42	3
60	3	46	40	62	3
63	3.5	47	40	40	3.5
65	3.5	52	45	40	3.5
68	3.5	54	47	35	3.5
70	3.5	54	47	40	3.5
70	3.5	57	50	48	3.5
72	3.5	57	50	45	3.5
72	3.5	57	50	50	3.5
75	3.5	57	50	50	3.5
77	3	60	54	55	3
83	3.5	66	59	53	3.5
85	3.5	65	58	60	3.5
87	3.5	67	60	53	3.5
87	3.5	67	60	60	3.5
87	3.5	67	60	65	3.5
87	4	68	60	60	4
94	3.5	72	65	60	3.5
87	3.5	72	65	65	3.5
87.5	1.95	69.12	65.22	64.5	2
88	3.5	67	60	60	3.5
88	3.5	72	65	65	3.5
92	3.5	77	70	67	3.5
93	3.5	75	68	60	3.5
94	3.5	77	70	70	3.5
95	3.5	77	70	65	3.5
95	4	78	70	70	4
97	3.48	77.14	70.18	62	3.5
97	3.5	82	75	74	3.5
100	5	85	75	70	5
103	3.525	70.8	63.75	73	3.5
105	3.5	82	75	75	3.5
105	3.5	87	80	70	3.5
107	4	83	75	74	4
115	5	100	90	75	5
128	3.8	92.6	85	103	4
108	3.5	72	65	75	3.5
108	3.5	77	70	98	3.5
108	5	80	70	90	5

## FB-08G 固体润滑轴承规格及公差 FB-08G Solid-lubricant Bushing Specification & Tolerance

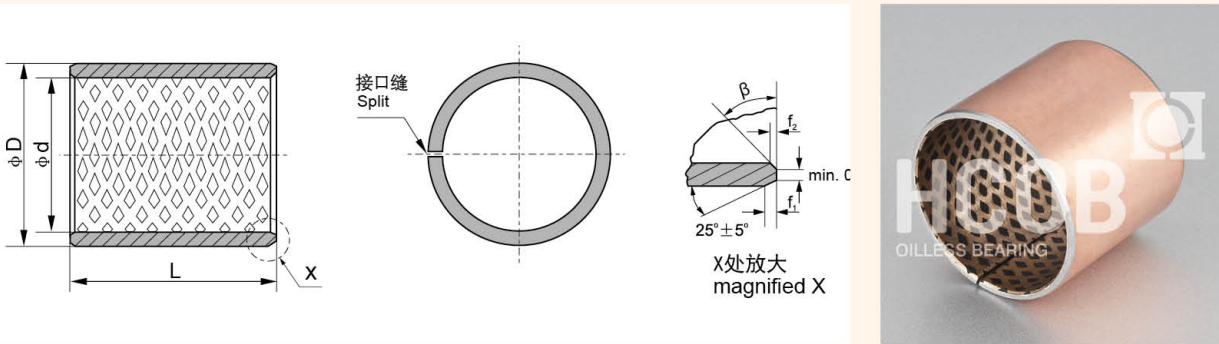

单位 Unit: mm

d	D	f <sub>1</sub>	f <sub>2</sub>	L <sup>0</sup> <sub>-0.40</sub>															
				10	15	20	25	30	35	40	50	60	70	80	90	100			
10	12	0.3	0.5	1010	1015	1020													
12	14			1210	1215	1220													
14	16			1410	1415	1420	1425												
15	17			1510	1515	1520	1525												
16	18			1610	1615	1620	1625												
18	20	1810	1815	1820	1825														
20	23	0.8	0.4	2010	2015	2020	2025												
22	25			2210	2215	2220	2225	2230											
24	27			2415	2420	2425	2430												
25	28			2515	2520	2525	2530												
28	32			2815	2820	2825	2830												
30	34	1.0	0.6	3015	3020	3025	3030	3035	3040										
32	36			3215	3220	3225	3230	3235	3240										
35	39			3515	3520	3525	3530	3535	3540										
40	44			4020	4025	4030	4035	4040	4050										
45	50			4520	4525	4530	4535	4540	4550										
50	55	1.2	0.8	5020	5025	5030	5035	5040	5050	5060									
55	60			5520	5525	5530	5535	5540	5550	5560									
60	65			6025	6030	6035	6040	6050	6060	6070									
65	70			6530	6535	6540	6550	6560	6570										
70	75			7030	7035	7040	7050	7060	7070	7080									
75	80	1.4	0.8	7530	7535	7540	7550	7560	7570	7580									
80	85			8030	8035	8040	8050	8060	8070	8080									
85	90			8540	8550	8560	8570	8580	8590										
90	95			9040	9050	9060	9070	9080	9090										
95	100			9550	9560	9570	9580	9590	95100										
100	105	1.4	0.8	10050	10060	10070	10080	10090	100100										
105	110			10550	10560	10570	10580	10590	105100										
110	115			11050	11060	11070	11080	11090	110100										
115	120			11550	11560	11570	11580	11590	115100										
120	125			12060	12070	12080	12090	120100											
125	130	12560	12570	12580	12590	125100													
130	135	13060	13070	13080	13090	130100													
135	140	13560	13570	13580	13590	135100													
140	145	14060	14070	14080	14090	140100													
145	150	14560	14570	14580	14590	145100													
150	155	15060	15070	15080	15090	150100													
155	160	15560	15570	15580	15590	155100													
160	165	16060	16070	16080	16090	160100													



**FB090 青铜卷制轴承**  
**FB090 Bronze-Wrapped Bearing**



**结构特性 Structure Characteristics**

以 CuSn8 青铜作为基板卷制而成的一种具有高承载、高耐磨的经济型薄壁铜基卷制轴承。根据不同的润滑条件，我们可以提供菱形油穴和油孔两种形式，菱形油穴用于油脂的润滑，通孔用于流体润滑，这样的设计可以确保在轴承运行初期就能建立润滑油膜，因此可以降低起始摩擦系数。

The bearing is made with CuSn8 bronze alloy which is featured with high load capacity and good anti-wearing characteristics. The diamond shape indents on the surface of the bearing serve as oil reservoir to generate oil film for the lubricating during the initial running. The bearings are mainly suitable for agriculture machineries and construction machineries applications.

**产品应用 Application**

农用机械、建筑机械、起重机、卡车底盘部件、输送机、升降机、卷扬机、校平等。

Agricultural machine, construction machine, crane, underpan parts, conveyor, elevator, winch, planing machine...

实际运用中根据使用工况的不同，基体可以采用不同牌号的合金，表面可以加工成其他形式的油孔和油槽。产品范围包括：FB090、FB091、FB092、FB094、FB09G。

According to the different working conditions, different grades of alloy can be used in the substrate, and the surface can be processed into other forms of oil holes and oil grooves. Product range includes: FB090、FB091、FB092、FB094、FB09G.

有关数据 Data	代号Grade	FB090	FB091	FB092	FB094	FB09G
	材料名称 Material	CuSn8P (Qsn8-0.3)	CuZn31Si (H68)	CuSn8P (Qsn8-0.3)	CuSn8P (Qsn8-0.3)	CuSn8P+石墨 (Qsn8-0.3+graphite)
除了目录中显示的标准产品外，还可以提供非标产品或根据客户要求订购。 We can also develop according to customers special request while out of this table.						
密度 g/cm <sup>3</sup> Density		8.8	8.4	8.8	8.8	8.3
最大动载 N/mm <sup>2</sup> Max Dynamic Load		40	90	40	40	40
最高线速度(脂润滑) m/s Max Linear Velocity (Grease)		2.5	1.5	2.5	2.5	2.5
最高PV值(脂润滑) N/mm <sup>2</sup> ·m/s Max PV value (Grease)		2.8	1.65	2.8	2.8	2.8
抗拉强度 N/mm <sup>2</sup> Pressure strength		>460	>440	>460	>460	>460
屈服强度 N/mm <sup>2</sup> Yield Strength		>260	>230	>260	>260	>230
硬度 HB hardness		90~150	80~120	90~150	90~150	90~150
相配轴 Mating Axis	硬度 HRC Hardness	≥50	≥50	≥50	≥50	≥50
	粗糙度 Roughness	0.4~1.0	0.4~1.0	0.4~1.0	0.4~1.0	0.4~1.0
适用温度 °C Working Temperature		-40~150	-40~150	-40~150	-40~150	-40~150
摩擦系数 Friction Coefficient		0.06~0.15	0.06~0.15	0.06~0.15	0.06~0.15	0.03~0.1
导热系数 W/m·K coefficient of heat conduction		58	71	58	58	58
线膨胀系数 (轴向) Linear expansion coefficient		18.5×10 <sup>-6</sup> /K	19.2×10 <sup>-6</sup> /K	18.5×10 <sup>-6</sup> /K	18.5×10 <sup>-6</sup> /K	18.5×10 <sup>-6</sup> /K
针对性运用领域 Pertinence applicaton		产品适用于起重机械、建筑机械、采矿机械，农业机械，森林机械等。 Application: Hoisting, mining machinery, Forest machinery, agricultural machinery etc.	产品运用于建筑机械、汽车制动系统机床工业等。 Application: construction machinery and machine tool, Brake system of Automobile etc.	产品广泛运用于农业机械、建筑机械、工程机械等。 Application: Agricultural Machinery Forestry machinery, Heavy duty construction machinery etc	它具有防止油脂倒漏，延长润滑时间，防止灰尘、沙等物质的渗透等优点。产品广泛运用于农业机械、建筑机械、工程机械等。 Can protect the grease leak from the bushing, prevent dust Application: Agricultural	它具有很低的摩擦系数，较好的耐磨性等优点，能在无油或少油的条件下工作。产品广泛应用于启动马达起升机，工程机械，汽车，卡车，拖拉机等。 Application: Starting motor hoisting machines and other construction machines, automobiles, tractors, trucks, machines tools and some mineral engines

## FB090 系列青铜卷制轴套 FB090 Bronze-Wrapped Bushes

### 油穴型式 Oil Sockets Format

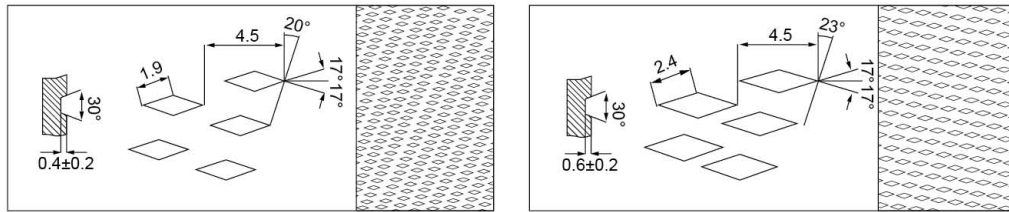

内径 ≤22

内径 >22

### 通孔型式 Oil Apertures Format

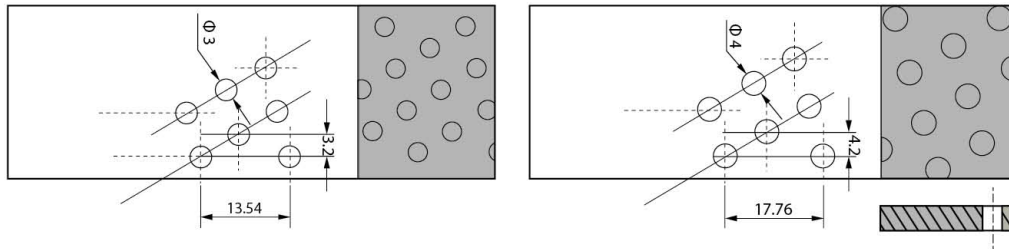

内径 Inside Dia. ≤ Φ25

内径 Inside Dia. > Φ25

### 标准衬套公差 (依据 DIW W91/1503547) Standard tolerance for bushes (As per to DIW W91/1503547)

标准直径 Standard Dia.	衬套外径尺寸 O.D.Size	相配座孔 Housing Bore	衬套内径尺寸 I.D.Size	相配轴径 Axle
10~18	+0.065 +0.030	+0.018 0	+0.046 0	-0.016 -0.043
18~30	+0.075 +0.035	+0.021 0	+0.052 0	-0.020 -0.020
30~50	+0.085 +0.045	+0.025 0	+0.062 0	-0.025 -0.064
50~80	+0.100 +0.055	+0.030 0	+0.074 0	-0.030 -0.076
80~120	+0.120 +0.070	+0.035 0	+0.087 0	-0.036 -0.090
120~180	+0.170 +0.100	+0.400 0	+0.100 0	-0.043 -0.106
180~250	+0.210 +0.130	+0.046 0	+0.115 0	-0.050 -0.122
250~315	+0.260 +0.170	+0.052 0	+0.130 0	-0.056 -0.137

## FB090 青铜轴套规格及公差 FB090 Bronze Sleeve Bushing Specification & Tolerance

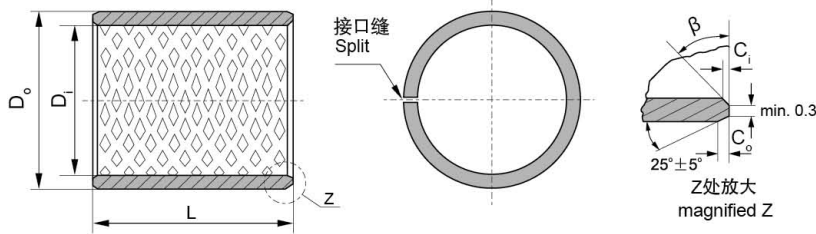

内外倒角 ID and OD chamfers

S <sub>3</sub>	C <sub>o</sub>	C <sub>i</sub>	β
0.75	0.5±0.3	0.25±0.2	35°±5°
1.00	0.6±0.3	0.30±0.2	35°±5°
1.50	0.7±0.3	0.50±0.3	35°±5°

S <sub>3</sub>	C <sub>o</sub>	C <sub>i</sub>	β
2.00	1.2±0.4	0.50±0.3	35°±5°
2.50	1.8±0.6	0.60±0.3	45°±5°

单位Unit: mm

内径 D <sub>i</sub> φd	外径 D <sub>o</sub> φD	长度 L <sup>0</sup> / <sub>-0.40</sub>												
		10	15	20	25	30	35	40	50	60	70	80	90	100
10	12	1010	1015	1020										
12	14	1210	1215	1220										
14	16	1410	1415	1420	1425									
15	17	1510	1515	1520	1525									
16	18	1610	1615	1620	1625									
18	20	1810	1815	1820	1825									
20	23	2010	2015	2020	2025									
22	25	2210	2215	2220	2225	2230								
24	27		2415	2420	2425	2430								
25	28		2515	2520	2525	2530								
28	31		2815	2820	2825	2830								
30	34		3015	3020	3025	3030	3035	3040						
32	36		3215	3220	3225	3230	3235	3240						
35	39		3515	3520	3525	3530	3535	3540						
40	44			4020	4025	4030	4035	4040	4050					
45	50			4520	4525	4530	4535	4540	4550					
50	55			5020	5025	5030	5035	5040	5050	5060				
55	60			5520	5525	5530	5535	5540	5550	5560				
60	65				6025	6030	6035	6040	6050	6060	6070			
65	70					6530	6535	6540	6550	6560	6570			
70	75					7030	7035	7040	7050	7060	7070	7080		
75	80					7530	7535	7540	7550	7560	7570	7580		
80	85					8030	8035	8040	8050	8060	8070	8080		
85	90					8530	8535	8540	8550	8560	8570	8580	8590	
90	95					9030	9035	9040	9050	9060	9070	9080	9090	
95	100							9540	9550	9560	9570	9580	9590	95100

**FB090 青铜轴套规格及公差**  
**FB090 Bronze Sleeve Bushing Specification & Tolerance**

单位Unit: mm

内径 D <sub>i</sub> φd	外径 D <sub>o</sub> φD	长度 L <sup>0</sup> <sub>-0.40</sub>									
		25	30	35	40	50	60	70	80	90	100
100	105					10050	10060	10070	10080	10090	100100
105	110					10550	10560	10570	10580	10590	105100
110	115					11050	11060	11070	11080	11090	110100
115	120					11550	11560	11570	11580	11590	115100
120	125						12060	12070	12080	12090	120100
125	130						12560	12570	12580	12590	125100
130	135						13060	13070	13080	13090	130100
135	140						13560	13570	13580	13590	135100
140	145						14060	14070	14080	14090	140100
145	150						14560	14570	14580	14590	145100
150	155						15060	15070	15080	15090	150100
155	160						15560	15570	15580	15590	155100
160	165						16060	16070	16080	16090	160100
165	170						16560	16570	16580	16590	165100
170	175						17060	17070	17080	17090	170100
175	180						17560	17570	17580	17590	175100
180	185						18060	18070	18080	18090	180100
185	190						18560	18570	18580	18590	185100
190	195						19060	19070	19080	19090	190100
195	200						19560	19570	19580	19590	195100
200	205						20060	20070	20080	20090	200100
205	210						20560	20570	20580	20590	205100
215	220						21560	21570	21580	21590	215100
225	230						22560	22570	22580	22590	225100
230	235						23060	23070	23080	23090	230100
240	245						24060	24070	24080	24090	240100
250	255						25060	25070	25080	25090	250100
260	265						26060	26070	26080	26090	260100
270	275						27060	27070	27080	27090	270100
280	285						28060	28070	28080	28090	280100
290	295						29060	29070	29080	29090	290100
300	305						30060	30070	30080	30090	300100

## FB090F 青铜翻边轴套规格及公差 FB090F Bronze Flange Bushing Specification & Tolerance

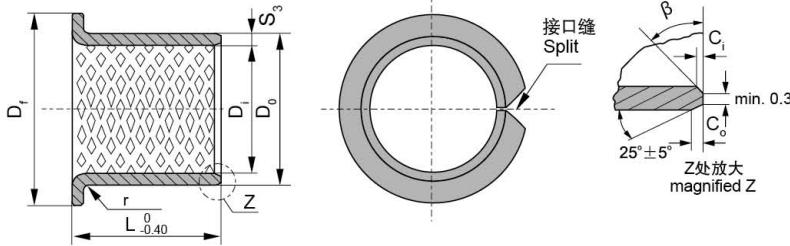

S <sub>3</sub>	1.0	1.5	2.0	2.5
r	1 <sup>±0.5</sup>	1±0.5	1.5±0.5	2±0.5

单位Unit: mm

内径 D <sub>i</sub> φd	外径 D <sub>o</sub> φD	法兰外径 D <sub>n</sub>	长度 L <sub>0</sub> <sup>-0.40</sup>													
			15	20	25	30	35	40	50	60	70	80	90			
25	28	35	25150	25200	25250											
30	34	45		30200	30250	30300										
35	39	50		35200	35250	35300	35350									
40	44	55			40250	40300	40350	40400								
45	50	60				45300	45350	45400	45500							
50	55	65				50300	50350	50400	50500							
55	60	70				55300	55350	55400	55500							
60	65	75				60300	60350	60400	60500	60600						
65	70	80				65300	65350	65400	65500	65600						
70	75	85					70350	70400	70500	70600	70700					
75	80	90					75350	75400	75500	75600	75700					
80	85	100					80350	80400	80500	80600	80700	80800				
90	95	110							90500	90600	90700	90800	90900			
100	105	120							100500	100600	100700	100800	100900			
110	115	130							110500	110600	110700	110800	110900			
120	125	140							120500	120600	120700	120800	120900			
130	135	155								130600	130700	130800	130900			
140	145	165								140600	140700	140800	140900			
150	155	180								150600	150700	150800	150900			
160	165	190								160600	160700	160800	160900			
170	175	200								170600	170700	170800	170900			
180	185	215								180600	180700	180800	180900			
190	195	225								190600	190700	190800	190900			
200	205	235								200600	200700	200800	200900			
225	230	260								225600	225700	225800	225900			
250	255	290								250600	250700	250800	250900			
265	270	305								265600	265700	265800	265900			
285	290	325								285600	285700	285800	285900			
300	305	340								300600	300700	300800	300900			

## FB092 青铜轴套规格及公差 FB092 Bronze Sleeve Bushing Specification & Tolerance

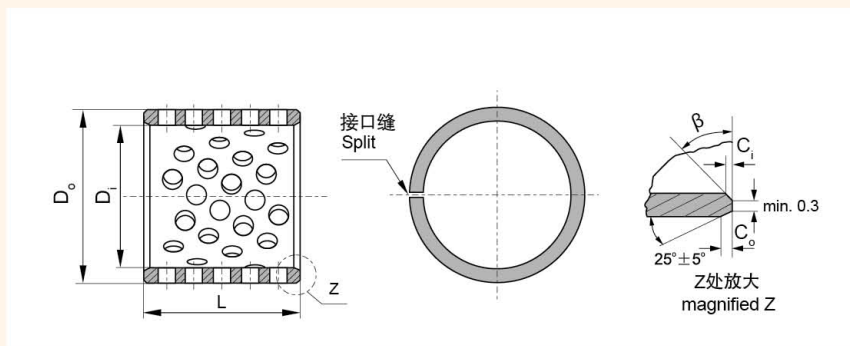

内外倒角 ID and OD chamfers

S <sub>3</sub>	C <sub>o</sub>	C <sub>i</sub>	β
0.75	0.5±0.3	0.25±0.2	35°±5°
1.00	0.6±0.3	0.30±0.2	35°±5°
1.50	0.7±0.3	0.50±0.3	35°±5°

S <sub>3</sub>	C <sub>o</sub>	C <sub>i</sub>	β
2.00	1.2±0.4	0.50±0.3	35°±5°
2.50	1.8±0.6	0.60±0.3	45°±5°

单位Unit: mm

内径 D <sub>i</sub> φd	外径 D <sub>o</sub> φD	长度 L <sup>0</sup> / <sub>-0.40</sub>													
		10	15	20	25	30	35	40	50	60	70	80	90	100	
10	12	1010	1015	1020											
12	14	1210	1215	1220											
14	16	1410	1415	1420	1425										
15	17	1510	1515	1520	1525										
16	18	1610	1615	1620	1625										
18	20	1810	1815	1820	1825										
20	23	2010	2015	2020	2025										
22	25	2210	2215	2220	2225	2230									
24	27		2415	2420	2425	2430									
25	28		2515	2520	2525	2530									
28	31		2815	2820	2825	2830									
30	34		3015	3020	3025	3030	3035	3040							
32	36		3215	3220	3225	3230	3235	3240							
35	39		3515	3520	3525	3530	3535	3540							
40	44			4020	4025	4030	4035	4040	4050						
45	50			4520	4525	4530	4535	4540	4550						
50	55			5020	5025	5030	5035	5040	5050	5060					
55	60			5520	5525	5530	5535	5540	5550	5560					
60	65				6025	6030	6035	6040	6050	6060	6070				
65	70					6530	6535	6540	6550	6560	6570				
70	75					7030	7035	7040	7050	7060	7070	7080			
75	80					7530	7535	7540	7550	7560	7570	7580			
80	85					8030	8035	8040	8050	8060	8070	8080			
85	90					8530	8535	8540	8550	8560	8570	8580	8590		
90	95					9030	9035	9040	9050	9060	9070	9080	9090		
95	100							9540	9550	9560	9570	9580	9590	95100	

## FB092 青铜轴套规格及公差 FB092 Bronze Sleeve Bushing Specification & Tolerance

内径 D <sub>i</sub> φd	外径 D <sub>o</sub> φD	长度 L <sup>0</sup> / <sub>-0.40</sub>									
		25	30	35	40	50	60	70	80	90	100
100	105					10050	10060	10070	10080	10090	100100
105	110					10550	10560	10570	10580	10590	105100
110	115					11050	11060	11070	11080	11090	110100
115	120					11550	11560	11570	11580	11590	115100
120	125						12060	12070	12080	12090	120100
125	130						12560	12570	12580	12590	125100
130	135						13060	13070	13080	13090	130100
135	140						13560	13570	13580	13590	135100
140	145						14060	14070	14080	14090	140100
145	150						14560	14570	14580	14590	145100
150	155						15060	15070	15080	15090	150100
155	160						15560	15570	15580	15590	155100
160	165						16060	16070	16080	16090	160100
165	170						16560	16570	16580	16590	165100
170	175						17060	17070	17080	17090	170100
175	180						17560	17570	17580	17590	175100
180	185						18060	18070	18080	18090	180100
185	190						18560	18570	18580	18590	185100
190	195						19060	19070	19080	19090	190100
195	200						19560	19570	19580	19590	195100
200	205						20060	20070	20080	20090	200100
205	210						20560	20570	20580	20590	205100
215	220						21560	21570	21580	21590	215100
225	230						22560	22570	22580	22590	225100
230	235						23060	23070	23080	23090	230100
240	245						24060	24070	24080	24090	240100
250	255						25060	25070	25080	25090	250100
260	265						26060	26070	26080	26090	260100
270	275						27060	27070	27080	27090	270100
280	285						28060	28070	28080	28090	280100
290	295						29060	29070	29080	29090	290100
300	305						30060	30070	30080	30090	300100



**FB092F 青铜翻边轴套规格及公差**

**FB092F Bronze Flange Bushing Specification & Tolerance**

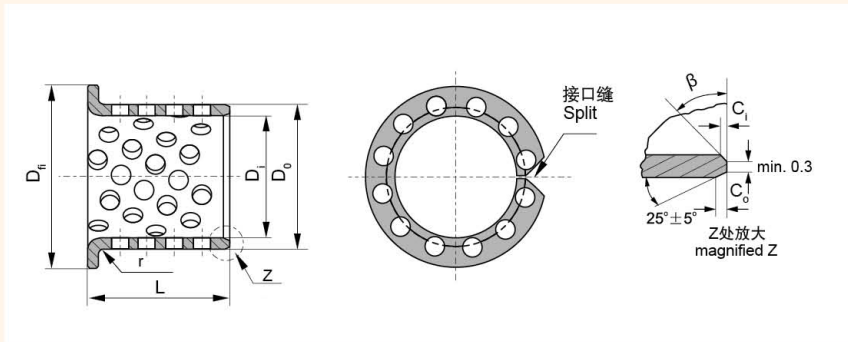

S <sub>3</sub>	1.0	1.5	2.0	2.5
r	1 <sup>+0.5</sup>	1±0.5	1.5±0.5	2±0.5

单位Unit: mm

内径 D <sub>i</sub> φd	外径 D <sub>o</sub> φD	法兰外径 D <sub>n</sub>	长度 L <sup>0</sup> / <sub>-0.40</sub>											
			15	20	25	30	35	40	50	60	70	80	90	
25	28	35	25150	25200	25250									
30	34	45		30200	30250	30300								
35	39	50		35200	35250	35300	35350							
40	44	55			40250	40300	40350	40400						
45	50	60				45300	45350	45400	45500					
50	55	65				50300	50350	50400	50500					
55	60	70				55300	55350	55400	55500					
60	65	75				60300	60350	60400	60500	60600				
65	70	80				65300	65350	65400	65500	65600				
70	75	85					70350	70400	70500	70600	70700			
75	80	90					75350	75400	75500	75600	75700			
80	85	95					80350	80400	80500	80600	80700	80800		
90	95	110							90500	90600	90700	90800	90900	
100	105	120							100500	100600	100700	100800	100900	
110	115	130							110500	110600	110700	110800	110900	
120	125	140							120500	120600	120700	120800	120900	
130	135	165								130600	130700	130800	130900	
140	145	165								140600	140700	140800	140900	
150	155	180								150600	150700	150800	150900	
160	165	190								160600	160700	160800	160900	
170	175	200								170600	170700	170800	170900	
180	185	215								180600	180700	180800	180900	
190	195	225								190600	190700	190800	190900	
200	205	235								200600	200700	200800	200900	
225	230	260								225600	225700	225800	225900	
250	255	290								250600	250700	250800	250900	
265	270	305								265600	265700	265800	265900	
285	290	325								285600	285700	285800	285900	
300	305	340								300600	300700	300800	300900	

其它产品  
Other products

				
SF-1(翻卷)	SF-1L	SF-TEX	TF	SF-2L
				
SF-2G	JF-800	JF-800F	JF-20	FB094
				
FB08G	FB08G	FB09G	FB090	FB090WC
				
FB09GWC	FU-1	FU-2	FU-3	FZH
				
FZL	FZL	FZP	FR	FD

## JDB 固体自润滑轴承 JDB Metallic self-lubricating bearings



### 结构特性 Structure Characteristics

JDB 系列固体自润滑轴承以高强度铜合金为基体并按工况需要有规律的排布一定比列的固体润滑剂，这种铜基镶嵌式固体润滑轴承结合了铜合金的高承载高耐磨及固体润滑剂的自润滑性能，使其在使用过程中大大降低了轴承和设备的维护成本。在此基础上开发了适合于经济型和耐冲击型运用的 JDB550 钢基铜合金镶嵌型固体润滑轴承、JDB250 铸铁镶嵌型固体润滑轴承和 JDB850 弥散型固体润滑轴承。

JDB solid self-lubricating bearing materials consist of high strength metal with solid lubricants embedded, the metal has high load capacity and solid lubricants provided low friction during the operation, this construction reduces maintenance cost for both bearing and machinery. Based on the above technique theory, we developed JDB550 steel shell cast bronze with graphite plug bearings for economic and impact load application, JDB250 steel with graphite plug bearings and JDB850 dispersed solid lubrication bearings for lower friction applications.

### 材料特点 Material Properties

- 可以长期使用而无需维护；
- 设计用于很高的静承载和动承载；
- 具有很低的且平稳的摩擦系数，无“粘着”现象；
- 具有耐粉尘、耐腐蚀、耐冲击和耐边缘负载能力；
- 金属基材具有很好的吸震能力；
- 能够在很宽的温度范围内使用；
- 适合于往复、旋转和摆动等启动频繁又难以形成油膜の場合；
- 具有极低的磨损率，使用寿命长。

- Allows maintenance-free and long-life operation;
- Suitable for high static and dynamic loads;
- With low and smoothly coefficient of friction and without stick-slip effects;
- Suitable for dirty, corrosion, impact load and edge loading;
- The base material provided a good shock-absorbing capacity;
- Can be used over a large temperature range;
- Suitable for reciprocating, rotating and oscillating movement with start frequency and difficulty to form oil film occasions;
- With low wear rate and long life service.

### 产品应用 Application

注塑机模架、汽车模具、工程机械、液压油缸、大型齿轮箱、冶金连铸机、列车支架、轧钢设备、矿山机械、船舶、气轮机、吊车支撑、食品机械、水轮机轴承等。



Injection molding machine, automotive moulds, hydrocylinder, gear case, gas turbine, water turbine, Crane support...

实际运用中根据使用工况的不同，基体可以采用不同牌号的合金，产品范围包括：JDB-1、JDB-2、JDB-3、JDB-4、JDB-5各系列产品。

According to the different working conditions, different type of alloy can be chosen, product range includes JDB-1、JDB-2、JDB-3、JDB-4、JDB-5.

代号 Grade	JDB-1	JDB-2	JDB-3	JDB-4	JDB-5
除了目录中显示的标准产品外，还可以提供非标产品或根据客户要求订购。 We can also develop according to customers special request while out of this table.					
材料 Material	CuZn25Al5Mn4Fe3	CuSn5Pb5Zn5	钢/teel+ CuZn25Al5Mn4Fe3	铸铁/HT250	钢/Gcr15
密度 g/cm <sup>3</sup> Density	8.0	8.0	7.6	7.3	7.8
硬度 HB Hardness	210-250	80-120	60-90	180-230	55-60
抗拉强度 N/mm <sup>2</sup> Tensile strength	>600	>200	>500	>250	>1500
延伸率 % Elongation	>10	> 4	> 10	-	-
线胀系数 10 <sup>-5</sup> /°C Coefficient of linear expansion	1.6-2.0	1.6-2.0	1.6-2.0	1.7-1.9	1.6-1.8
最高使用温度 °C Max Working Temperature	300	350	300	400	350
最大动承载 P (N/mm <sup>2</sup> ) Max Move Load Capacity	100	60	70	60	250
最大滑动速度 V (m/s) Max Sliding Speed	干0.4 油5	2	2	0.5	0.1
最高PV值 (N/mm <sup>2</sup> ·m/s) Max PV Value Limit	3.8	0.5	0.6	0.8	2.5
摩擦系数μ Friction coefficient	油润滑: 0.03 Oil Lubrication: 0.03			干摩擦: 0.16 Dry Friction: 0.16	

## 固体润滑剂 Solid Lubricants

固体润滑剂 Lubricant	特性 Features	典型用途 Typical application
高纯石墨+添加剂 Graphite+add 	很好的耐磨性和化学稳定性，使用温度 <400°C Good wear performance and chemical stability, temperature limit 400°C	应用于一般机械，在大气中使用 Suit for general machines and under atmosphere
PTFE+添加剂 PTFE+add 	极低的摩擦系数和很好的水润滑性，使用温度 <300°C Lowest friction coefficient and good water lubrication, temperature limit 300°C	应用于水、海水润滑，如船舶 Suit for water and seawater lubricant, such as ship

JDB 自润滑直套轴承标准公制尺寸

JDB Self-lubricating Sleeve Bearings Standard Metric Size

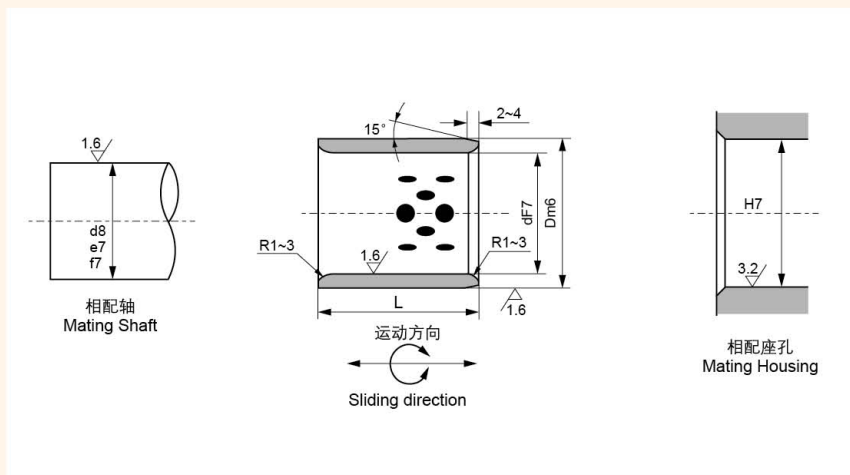

材料：高力黄铜+固体润滑剂  
Material: CuZn25Al5Mn4Fe3  
+Graphite (650#SP)

单位unit:mm

d	D	d F7	D m6	L														
				8	10	12	15	16	20	25	30	35	40	50	60	70	80	
8	12	8	12	081208	081210	081212	081215											
10	14	10	14	101408	101410	101412	101415	101416	101420									
12	18	12	18		121810	121812	121815	121816	121820	121825	121830							
13	19	13	19		131910	131912	131915	131916	131920	131925	131930							
14	20	14	20		142010	142012	142015	142016	142020	142025	142030							
15	21	15	21		152110	152112	152115	152116	152120	152125	152130	152135						
16	22	16	22		162210	162212	162215	162216	162220	162225	162230	162235	162240					
18	24	18	24		182410	182412	182415	182416	182420	182425	182430	182435	182440					
20	28	20	28		202810	202812	202815	202816	202820	202825	202830	202835	202840	202850				
22	32	22	32			223212	223215	223216	223220	223225	223230	223235	223240	223250				
25	33	25	33			253312	253315	253316	253320	253325	253330	253335	253340	253350	253360			
30	38	30	38			303812	303815	303816	303820	303825	303830	303835	303840	303850	303860			
35	45	35	45						354520	354525	354530	354535	354540	354550	354560	354570		
40	50	40	50						405020	405025	405030	405035	405040	405050	405060	405070	405080	
45	55	45	55								455530	455535	455540	455550	455560	455570	455580	
50	60	50	60								506030	506035	506040	506050	506060	506070	506080	

**JDB 自润滑直套轴承标准公制尺寸**  
**JDB Self-lubricating Sleeve Bearings Standard Metric Size**

d	D	d F7	D m6	L <sup>-0.10</sup> / <sub>-0.30</sub>													
				30	35	40	50	60	70	80	100	120	130	140	150		
50	62	50	62	+0.050 +0.025	506230	506235	506240	506250	506260	506270							
50	65	50			506530	506535	506540	506550	506560	506570	506580	5065100					
55	70	55	70		557030	557035	557040	557050	557060	557070	557080	5570100					
60	74	60	75	+0.030 +0.011	607430	607435	607440	607450	607460	607470	607480	6074100					
60	75	60	75		607530	607535	607540	607550	607560	607570	607580	6075100					
63	75	63	75		637535	637540	637550	637560	637570	637580	6375100						
65	80	65	80		658035	658040	658050	658060	658070	658080	6580100						
70	85	70	85	+0.060 +0.030	708535	708540	708550	708560	708570	708580	7085100						
70	90	70	90		709035	709040	709050	709060	709070	709080	7090100						
75	90	75	90		759040	759050	759060	759070	759080	7590100							
75	95	75	95	+0.035 +0.013	759540	759550	759560	759570	759580	7595100	7595120						
80	96	80	96		809640	809650	809660	809670	809680	8096100	8096120	8096130					
80	100	80	100		8010040	8010050	8010060	8010070	8010080	80100100	80100120	80100130	80100140				
90	110	90	110		9011050	9011060	9011070	9011080	90110100	90110120	90110130	90110140					
100	120	100	120	+0.071 +0.036	10012060	10012070	10012080	100120100	100120120	100120130	100120140						
110	130	110	130		11013080	110130100	110130120	110130130	110130140								
120	140	120	140		12014080	120140100	120140120	120140130	120140140								
125	145	125	145		125145100	125145120	125145130	125145140									
130	150	130	150	+0.040 +0.015	130150100	130150120	130150130	130150140	130150150								
140	160	140	160		+0.083 +0.043	140160100	140160120	140160130	140160140	140160150							
150	170	150	170		150170100	150170120	150170130	150170140	150170150								
160	180	160	180		160180100	160180120	160180130	160180140	160180150								

JFB 自润滑翻边轴承标准公制尺寸

JFB Self-lubricating Flange Bearings Standard Metric Size

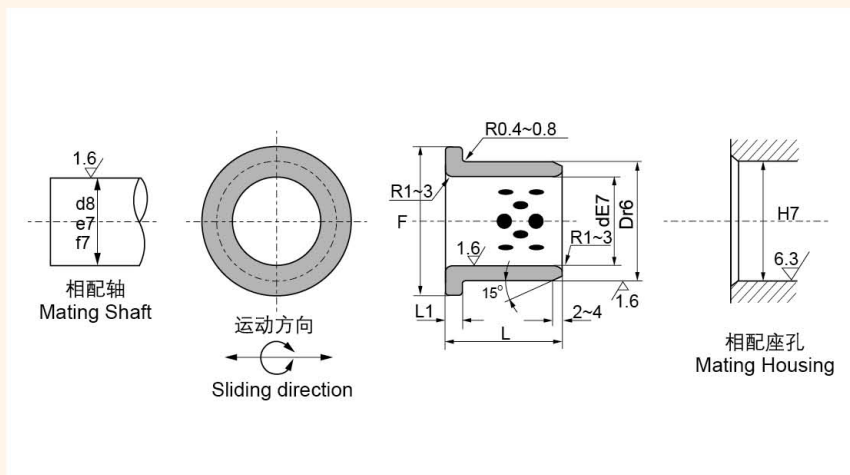

材料：高力黄铜+固体润滑剂  
Material: CuZn25Al5Mn4Fe3  
+Graphite (650#5P)

单位unit:mm

d	D	d E7	D r6	F	L <sub>1</sub>	L <sup>-0.10</sup> / <sub>-0.30</sub>														
						15	20	25	30	35	40	50	60	80	100					
10	14	10	14 <sup>+0.040</sup> / <sub>+0.025</sub>	22	2	1015	1020													
12	18	12	18 <sup>+0.034</sup> / <sub>+0.023</sub>	25		1215	1220													
13	19	13	19	26		1315	1320													
14	20	14	20 <sup>+0.050</sup> / <sub>+0.032</sub>	27	3	1415	1420	1425												
15	21	15	21 <sup>+0.041</sup> / <sub>+0.028</sub>	28		1515	1520	1525	1530											
16	22	16	22	29		1615	1620	1625	1630											
20	30	20	30	40			2020	2025	2030	2035										
25	35	25	35 <sup>+0.061</sup> / <sub>+0.040</sub>	45			2520	2525	2530	2535	2540									
30	40	30	40 <sup>+0.050</sup> / <sub>+0.034</sub>	50			3020	3025	3030	3035	3040	3050								
35	45	35	45	60	5			3525	3530	3535	3540	3550								
40	50	40	50 <sup>+0.075</sup> / <sub>+0.050</sub>	65					4030	4035	4040	4050								
45	55	45	55	70					4530	4535	4540	4550	4560							
50	60	50	60 <sup>+0.060</sup> / <sub>+0.041</sub>	75						5035	5040	5050	5060							
55	65	55	65	80							5540	5550	5560							
60	75	60	75 <sup>+0.062</sup> / <sub>+0.043</sub>	90						6040	6050	6060	6080							
70	85	70	85 <sup>+0.090</sup> / <sub>+0.060</sub>	105	7.5						7050	7060	7080							
75	90	75	90 <sup>+0.073</sup> / <sub>+0.051</sub>	110							7550	7560	7580	75100						
80	100	80	100	120									8060	8080	80100					
90	110	90	110 <sup>+0.076</sup> / <sub>+0.054</sub>	130	10								9060	9080	90100					
100	120	100	120 <sup>+0.107</sup> / <sub>+0.072</sub>	150									10060	10080	100100					
120	140	120	140 <sup>+0.088</sup> / <sub>+0.063</sub>	170									12060	12080	120100					

JTW 自润滑止推垫片标准公制尺寸  
 JTW Self-lubricating Thrust Washer Standard Metric Size

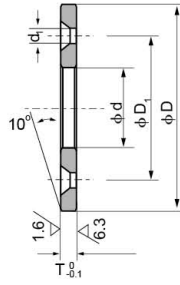
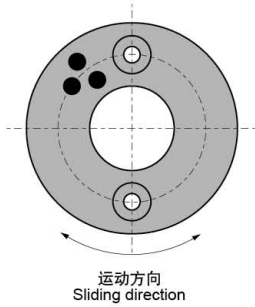

材料：高力黄铜+固体润滑剂  
 Material: CuZn25Al5Mn4Fe3  
 +Graphite (650#SP)

单位Unit: mm

型号规格 Standard No.	φd	φD	T <sub>-0.10</sub> <sup>0</sup>	螺孔 Bolt Hole				
				φD <sub>1</sub>	平头螺钉 Crop Bolt	φd <sub>1</sub>	孔数 Bore Number	
JTW-10	10.2	30	3	20	M3	3.5	2	
JTW-12	12.2	40		35				
JTW-13	13.2							28
JTW-14	14.2							
JTW-15	15.2							
JTW-16	16.2	50	40	M5	6			
JTW-18	18.2					5		
JTW-20	20.2							45
JTW-25	25.2	70	50	M6	7			
JTW-30	30.2					60		
JTW-35	35.2						7	
JTW-40	40.2	80	60	M8	9	4		
JTW-45	45.3						90	
JTW-50	50.3							8
JTW-55	55.3	110	85	M10	11			
JTW-60	60.3						120	
JTW-65	65.3							125
JTW-70	70.3	130	100	M8	9			
JTW-75	75.3						140	
JTW-80	80.3							10
JTW-90	90.5	170	140	M10	11			
JTW-100	100.5					190		
JTW-120	120.5	200	175					



## JDBB 自润滑翻边轴套标准公制尺寸 JDBB Self-lubricant Flange Bushings Standard Metric Size

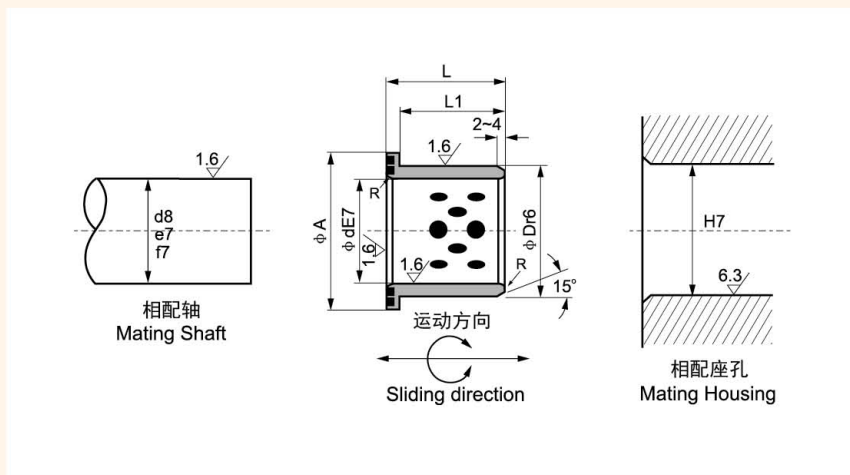

材料：高力黄铜+固体润滑剂  
Material: CuZn25Al5Mn4Fe3  
+Graphite (650#SP)

单位unit:mm

型号规格 Standard No.	φd E7		φD r6		φA	L1	L
JDBB-12×15	12	+0.050 +0.032	18	+0.034 +0.023	25	11	15
JDBB-16×20	16		22		30	15	20
JDBB-20×25	20	+0.061 +0.040	28	+0.041 +0.028	36	20	25
JDBB-25×30	25		33		43	25	30
JDBB-30×35	30	+0.075 +0.050	38	+0.050 +0.034	48	30	35
JDBB-40×45	40		50		60	40	45
JDBB-50×55	50	+0.090 +0.060	62	+0.060 +0.041	75	49	55
JDBB-60×65	60		74		90	58	65

## JSP 滑板标准公制尺寸 JSP Wear Plates Standard Metric Size

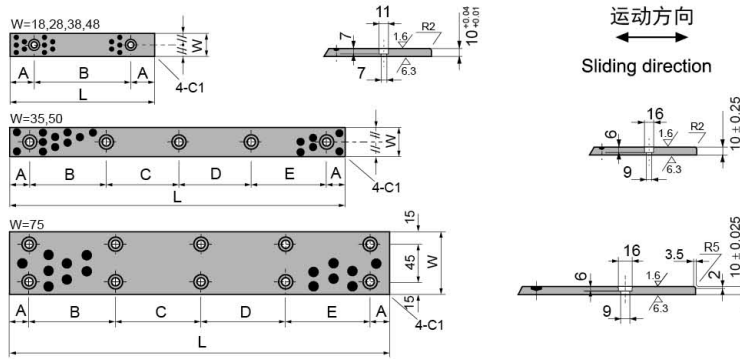

材料：高力黄铜+固体润滑剂  
Material: CuZn25Al5Mn4Fe3  
+Graphite (650#SP)

单位Unit: mm

型号规格 Standard No.	W	L	A	B	C	D	E	平头螺钉尺寸 Flat Head Screw Size	孔数 Q'ty of holes	
JSP-1875	18	75	15	45				M6	2	
JSP-18100		100		50						
JSP-18125		125	25	75						
JSP-18150		150		100						
JSP-2875	28	75	15	45				M6	2	
JSP-28100		100		50						
JSP-28125		125	25	75						
JSP-28150		150		100						
JSP-35100	35	100		60				M8	3	
JSP-35150		150		55	55					
JSP-35200		200	20	55	50	55				
JSP-35250		250		70	70	70				
JSP-35300		300		65	65	65	65			
JSP-35350		350		80	75	75	80			
JSP-3875	38	75	15	45				M6	2	
JSP-38100		100		50						
JSP-38125		125	25	75						
JSP-38150		150		100						
JSP-4875	48	75	15	45				M6	2	
JSP-48100		100		50						
JSP-48125		125	25	75						
JSP-48150		150		100						
JSP-50100	50	100		60				M8	3	
JSP-50150		150		55	55					
JSP-50200		200	20	55	50	55				
JSP-50250		250		70	70	70				
JSP-50300		300		65	65	65	65			
JSP-50400		400		90	90	90	90			
JSP-75150	75	150	20	110				M8	4	
JSP-75200		200		80	80					
JSP-75250		250		105	105					
JSP-75300		300		85	90	85				
JSP-75400		400		120	120	120				
JSP-75500		500		115	115	115	115			

**JFFB 自润滑轴瓦**  
**JFFB Half-Bearing**

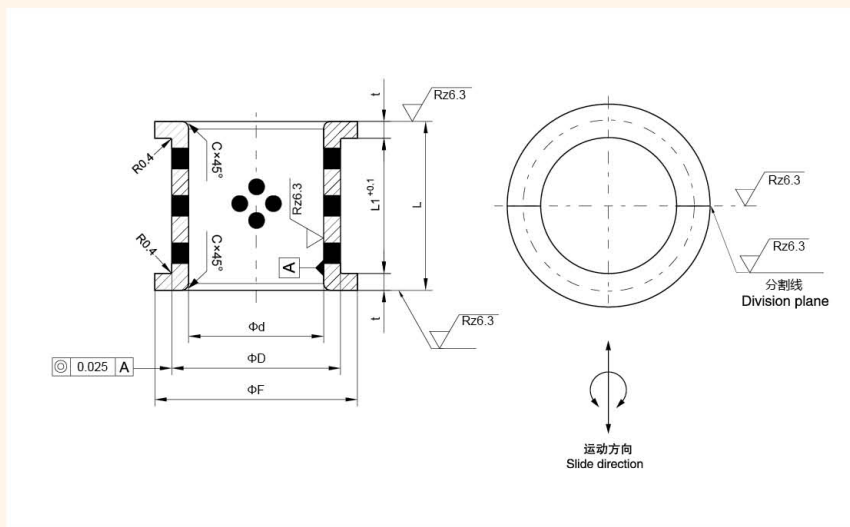

材料：高力黄铜+固体润滑剂  
Material: CuZn25Al5Mn4Fe3  
+Graphite (650#SP)

单位unit:mm

产品代号 Part No.	I.D. $\phi d$ 内径 H7	O.D. $\phi D$ 外径	$\phi F$ d11	L h12	$L_1^{+0.1}$ 0	t	C
JFFB-030	30	38	s6	48	34	22	1
JFFB-035	35	45	"	55	45	32	"
JFFB-040	40	50	"	60	50	35	"
JFFB-045	45	55	"	65	55	40	"
JFFB-050	50	60	"	70	60	45	"
JFFB-060	60	70	"	80	70	50	2
JFFB-070	70	85	"	95	80	60	"
JFFB-080	80	95	"	110	95	70	"
JFFB-090	90	105	"	120	105	80	"
JFFB-100	100	115	"	130	115	90	"
JFFB-110	110	125	r6	140	125	100	"
JFFB-120	120	135	"	150	140	110	"
JFFB-140	140	160	"	175	160	120	"
JFFB-160	160	180	"	200	180	140	"

## JDB600 油沟铜衬套 JDB600 Oil Groove Bronze Bushing



JDB600铜套，是一种以油沟涌油作为润滑的高力黄铜轴承。该产品具有传统的锡青铜轴承功能，由于采用高力黄铜(ZCuZn25Al6Fe3Mn3)后，它的HB硬度提高了一倍，所以在低速的场合使用该产品，比一般青铜套寿命可以延长一倍，而且其承载压力大，能适应重载的场合使用。并可按客户要求提供如下材质。

JDB600 copper sleeve, is a kind of groove Bay oil as lubrication oil of high strength brass bearings. The product has a function of the traditional bronze bearings, the use of high strength brass (ZCuZn25Al6Fe3Mn4), its hardness HB doubling the occasion so low to use the product, than the average life span can be extended twice bronze sets, and its bearing pressure, can adapt to overloaded occasions.

材料型号 Material type	600#Strong Cast bronze 高力黄铜	600S1 CuSn5Zn5Pb5	600S2 CuAl10Ni5Fe5	600S3 CuSn12	600S4 CuSn10Pb10	600S5 CuZn25Al5
化学元素 Chemical elements						
Cu	65	85	80	88	80	65
Sn		5		12	10	
Pb		5			10	
Zn	25	5				25
Ni			5			
Al	6		10			6
Fe			5			
Mn	4					4
密度 Density	8.0	8.8	7.6	8.8	8.9	8.0
屈服强度 Yield point	>350	>90	>260	>150	>100	>450
抗拉强度 Tensile Strength	>750	>250	>500	>270	>210	>800
延伸率 Extension Rate	>12	>15	>10	>5	>8	>8
硬度 Hardness	210	70	150	95	75	250

JDB600精加工铜合金轴套提供了简单、经济的轴承运用方式，具有承载高，耐腐蚀性好，尺寸加工任意性等特点。同时HCOB可以根据不同的使用情况提供不同牌号的铜合金，并按照要求加工出不同的形式，它比卷制类铜轴承具有更高尺寸精度。

Machined st bronze bearings offer technically and economically favorable bearings solutions. It is with high load pability, low weight and good corrosion sistance. HCOB can offer diffe-ant types of bronze alloys accoring to the required life time, service etc. The tolerance is much tighter than wrapped bronze bushes.

### 技术参数 Technical Parameters

最大承载压力	250N/mm <sup>2</sup>	最高适用温度	300°C
最高线速度	5m/s	硬度	HB > 180
摩擦系数	<0.14	允许最高 PV 值 (干)	1.65N/mm <sup>2</sup> .m/s

### 可供形式 Available

直套 Cylindrical bushes 垫片 Flange bushes JDB600可以根据客户要求加工，公差参照标准的JDB尺寸表。  
翻边 Thrust washers 滑板 Plate JDB600 supplied by customer ordering, the tolerance is according to JDB standard dimension.

### 油槽 OilGroove



**JDB-3 钢基铜合金镶嵌型固体润滑轴承**  
**JDB-3 Steel Shell Cast Bronze With Graphite Plug Bushes**



**材料特点 Material Properties**

1. 结合了铜合金的耐磨性和钢的高机械强度性能；
2. 可以根据工况要求铸造不同的铜合金材料包括低摩擦性能的铅铜合金；
3. 由于内外层材料具有的不同摩擦系数，可以防止轴承在高载低速工况下的窜动和走外圆；
4. 可以根据需要在工作面覆盖或镶嵌固体润滑剂以达到自我润滑的目的；
5. 相比纯铜套更具有成本优势，节约利用资源；
6. 可以进行后期加工，比如钢基体的热处理、合金层车加工等；
7. 可以根据设计需要在不同的面或者复杂的面上进行一层或多层的铜合金铸造；
8. 与传统的铜套在使用特性上具有类似的特性，可以适合于不同温度下不同润滑条件下的工况；
9. 相比纯铜套具有更好的机械承载性能，特别是抗冲击强度。

1. Combined with the resistance of copper alloy and high mechanical strength properties of steel;
2. Different cast copper alloy material is available according to work condition, including lower friction lead bronze;
3. The different coefficient of friction of the inner and outer material can protect the axial and rotating movement of the bearing in the housing under extremely high load with low speed;
4. The solid lubricant plug can be embedded to achieve the self-lubricating performance;
5. Compare with pure bronze bearing, the cost is reduced obviously;
6. The steel backing allowed to heat treatment to get high hardness, meanwhile the inner layer can be re-machined if necessary;
7. The bronze layer can be casted on one or more layers to complex structure;
8. This material have same characteristic as pure bronze bearing, suitable for wide temperature range, different oil condition;
9. The CRB650GT have better mechanical load performance compare with bronze material, especially the impact strength.

## JDB-3 钢基铜合金镶嵌型固体润滑轴承

## JDB-3 Steel shell cast bronze with graphite plug bushes



### 基材特征 Structure

在优质碳钢表面浇铸高强度铜合金作为轴承的基础材料，这种制造工艺使得铜和钢结合面达到完全的冶金结合，在降低了材料成本的同时也提高了其承载能力；而根据使用工况在其工作面镶嵌固体润滑剂大大降低了轴承的摩擦系数并达到了自我润滑的目的。

Steel shell with cast bronze bearing material liner with specially formulated solid lubricants embedded into the holes in the liner material. The process of casting bronze on steel achieves an integral metallurgical structure between bronze and steel with an increased carrying capacity while the material cost is considerably reduced. The solid lubricant can reduce the coefficient of friction and performs the self-lubricating function.

### 金相组织 Features

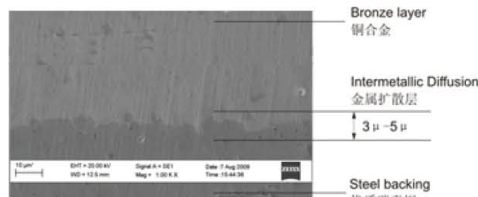
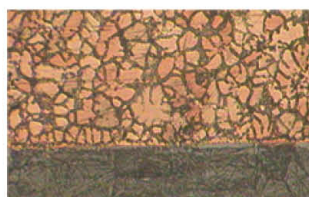

Bronze layer  
铜合金

Intermetallic Diffusion  
金属扩散层

3 μ - 5 μ

Steel backing  
铁质衬套

### 石墨镶嵌方式 Graphite Mosaic



A: 内径 (ID) ≤ 100

B: 内径 (ID) ≥ 100

### 材料特点 Material Properties

从金相图可以看出临界区的钢与铜合金之间产生了相互扩散，这种在铸造过程中产生的扩散层大约在3μ~5μ之间使得两种材料达到了完全的冶金结合形成了很好的结合强度，在任何情况下这种机械强度超过了铜合金本身。

钢和铜相互之间扩散的组织结构提供了这种材料优秀的机械性能，同时可将轴承运作过程中产生的热量及时转移。薄壁的铜合金层使得这种双层材料的热膨胀系数相近，因此JDB-3材料可以在铸造后根据需要进行热处理，也就是说这种新型的材料可以确保在使用过程中保持很高的精度和机械配合。

- 结合了铜合金的耐磨性和钢的高机械强度性能；
- 可以根据工况要求铸造不同的铜合金材料包括低摩擦性能的铅铜合金；
- 由于内外层材料具有的不同摩擦系数，可以防止轴承在高载低速工况下的窜动和走外圆；
- 可以根据需要在工作面覆着或镶嵌固体润滑剂以达到自我润滑的目的；
- 相比纯铜套更具有成本优势，节约利用资源；
- 可以进行后期加工，比如钢基体的热处理、合金层车加工等；
- 可以根据设计需要在不同的面或者复杂的面上进行一层或多层的铜合金铸造；
- 与传统的铜套在使用特性上具有类似的特性，可以适合于不同温度下不同润滑条件下的工况；
- 相比纯铜套具有更好的机械承载性能，特别是抗冲击强度。

JDB-3 combines the advantages of a metallic bearing and the self lubricating of graphite. It is particularly good for low-speed and high load applications, where external lubrication is not practical. The new based material provides economic solution and even good resistance to shock loads.

- Cylindrical bushes
- Thrust washers
- Flange bushes
- Non-standard parts as design
- JDB-3 supplied by customer ordering, the tolerance is according to JDB-3 standard dimension.

This type of products can be widely used under high temperature and high load with low speed conditions, such as successive casting machinery, mineral machinery, injection molding machinery, dock machinery and so on

**JDB-3 钢基铜合金镶嵌型固体润滑轴承**  
**JDB-3 Steel shell cast bronze with graphite plug bushes**

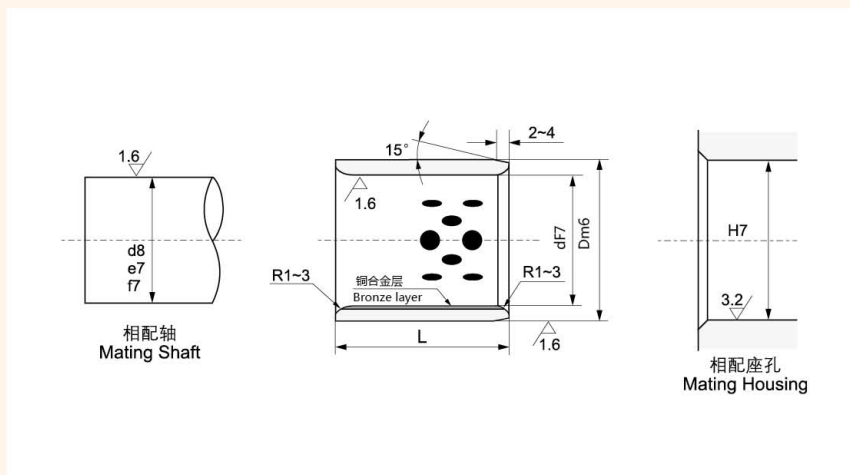

OD 外径: S45C  
 ID 内径: KSOB550铜合金+石墨  
 Graphite

单位unit:mm

ID	F7	OD	m6	Wall Thick 壁厚	Bronze Thick 铜层厚	L-0.10/0.30															
						30	35	40	50	60	70	80	90	100	120	130	140	150	200		
50	+0.050 +0.025	60	+0.030 +0.011	5	1.5	●	●	●	●	●	●										
"	"	65	"	7.5	"	●	●	●	●	●	●	●	●								
55	+0.060 +0.030	70	"	"	"	●	●	●	●	●	●										
60	"	75	"	"	"	●	●	●	●	●	●	●	●								
65	"	80	"	"	"				●	●	●	●									
70	"	85	+0.035 +0.013	"	"		●	●	●	●	●	●	●	●							
"	"	90	"	10	"				●	●	●	●									
75	"	90	"	7.5	"					●	●	●	●								
"	"	95	"	10	"					●	●	●	●	●							
80	"	95	"	7.5	"			●	●	●	●	●	●	●	●						
"	"	100	"	10	"			●	●	●	●	●	●	●	●	●					
85	+0.071 +0.036	100	"	7.5	"			●	●	●	●	●	●	●	●	●	●				
90	"	110	"	10	2				●	●	●	●	●	●	●	●	●	●			
100	"	120	"	"	"					●	●	●	●	●	●	●	●	●			
110	"	130	+0.040 +0.015	"	"						●	●	●	●	●	●	●	●			
120	"	140	"	"	"							●	●	●	●	●	●	●			
125	+0.083 +0.043	145	"	"	"								●	●	●	●	●	●			
130	"	150	"	"	"									●	●	●	●	●			
140	"	160	"	"	"										●	●	●	●			
150	"	170	"	"	"											●	●	●			
160	"	180	"	"	"												●	●			
170	"	190	+0.046 +0.017	"	"													●	●		
180	"	200	"	"	"														●		
190	+0.096 +0.050	210	"	"	"														●		
200	"	230	"	15	3														●		
225	"	255	+0.046 +0.017	"	"														●		
250	"	280	"	"	"														●		
280	+0.108 +0.056	320	+0.057 +0.021	20	4														●		
300	"	340	"	"	"														●		
350	+0.119 +0.062	390	"	"	"														●		
400	"	450	+0.063 +0.023	25	5														●		
450	+0.131 +0.068	500	"	"	"														●		

其它产品  
Other products

				
JDB-1	JDB-2	JDB-3	JDB-4	JDB-5
				
JDB	JFBB	JTW	JFFB	JSP
				
JSL	JDBS	JDBS	JGB	JDB (PTFE)
				
JEGB / JEGBK	SHTZ/SHTNZ	MPTZ/MPTSZ / MPTNZ	MPIZ/MPIZ	MPCZ/MPCTZ
				
DIN9834	JEFW	JPBW/JPBF	2087.72	2087.70



其它产品  
Other products

				
JDB	2081.75	2081.74	HGB250	模架铜片
				
JPW	JFRP	JESW	JTLP	JTWP
				
JUCF/JCUS	HCRB	JCBS	JCBSP	塑胶模具用导板
				
JSPW	JSPS	JDB600	JDB600	JDB600
				
JDB600	JDB600	JDB600	JDB600	JDB600



We Have Long Been Committed to the Development  
and Manufacture of High-Quality Bearings  
我们长期致力于高品质轴承的开发与制造



**嘉善华承无油轴承有限公司**

地址 浙江省嘉善县干窑镇亭耀东路 36 号  
邮编 314107  
电话 0573-8499 5899 18006831819  
传真 0573-8499 3899  
网站 [www.cnhcob.com](http://www.cnhcob.com)  
邮箱 [jshc\\_zpy@163.com](mailto:jshc_zpy@163.com)

**JIASHAN HUACHENG OILLESS BEARING CO., CTD.**

Add 36 Tingyao East Road, Ganyao Town, Jiashan County,  
Zhejiang Province, China Code 314107  
Tel +86-573-8499 5899 18006831819  
Fax +86-573-8499 3899  
Web [www.cnhcob.com](http://www.cnhcob.com)  
E-mail [jshc\\_zpy@163.com](mailto:jshc_zpy@163.com)